

# Simplified FE Simulation of Frontal Occupant Restraint Systems

Richard Brown, David Coleman, Ian Bruce

Jaguar Land Rover, Coventry, UK. Arup, Solihull, UK.

## Summary:

The behaviour of crash test dummies, in frontal impact, forms the basis of legislative compliance and consumer information test programmes, such as EuroNCAP. Dummy injury values depend on interior component systems, including airbags, seatbelts, steering column, knee bolster systems and seats, and development of these components, and tuning of the whole system, is a challenging task, especially since the test requirements are becoming steadily more demanding.

In the pursuit of reducing development times and optimising to the most efficient designs in the virtual world, before committing to production tooling, vehicle manufacturers are embracing CAE-led engineering, and physical prototype testing is reducing. In many cases, certification tests are carried out without prior prototype validation testing. This requires simulation tools to be truly predictive. Additionally, pressure to reduce development times demands efficient and integrated processes.

Traditionally, simulation of frontal occupant crash behaviour has been carried out using parametric multi-body dynamics software. This process is not fully predictive, and relies on tuning the model to test results. It is used for target setting, post-test tuning, and quick back-to-back comparisons. More recently, predictive FE simulation, employed for many years in structural analysis, has become a well established tool for the detailed development of individual components, and systems, based on geometry and material properties. This has been enabled by increasingly reliable restraints and dummy models.

Currently, both the mbd and the FE approaches are often used in parallel, and figure 1 illustrates how they are focussed on different parts of the range of activities from system tuning to component development. The gap between them represents the consideration of complex geometry in a parametric environment.

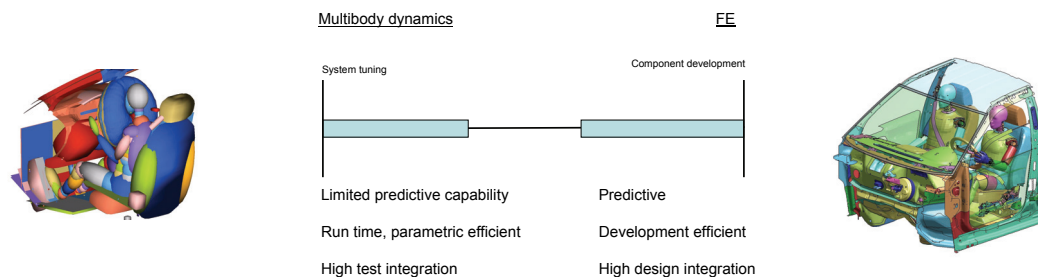

Figure 1. Focus of mbd and FE simulation approaches

This parallel development route has significant drawbacks; the maintenance of two process streams is inefficient, and brings issues of flexibility of skills and additional training needs, it is necessary to maintain two parallel component model databases, information flow between the two models requires added input and control, and creating hybrid models is challenging and not always feasible in a production environment. Additionally, the two systems provide two types of answers. When reporting

beyond the immediate Safety and restraints Technical community this has the potential to cause some level of confusion.

Against this background, a method was sought to utilise better the predictive capability of the FE model, whilst retaining a parametric representation for system tuning, and, at the same time, addressing the issues described above. To this end, a methodology has been developed to replace the dual-software approach by a unified, DYNA-based, alternative. The aim was to define a set of parametric DYNA representations of the occupant component systems, which was fully compatible with the standard DYNA modelling techniques, offered the same flexibility as multibody dynamics models, enabled any level of hybrid parametric / geometric model to be constructed, and had a usable interactive run time. Direct integration into the structural model would allow an efficient consideration of structural motion and intrusion. This FE methodology was intended to allow detail predictive capability based on geometry, where required, and provide a parametric capability where this is appropriate.

For each relevant component system, the interactions with neighbouring components, and the internal load generation mechanisms were identified. On the basis of this analysis, simple representations using springs, planes, and masses were developed. The knee bolster model principle is illustrated in figure 2.



Figure 2. Knee bolster system

A comparison of the simple and original DYNA models was carried out, using component validation load cases, and the simple model was refined to reflect the behaviour of the standard model. A full sled system model was also created, and again compared with the original standard model to confirm the results in the system environment. Figure 3 shows an example of the level of agreement achieved.

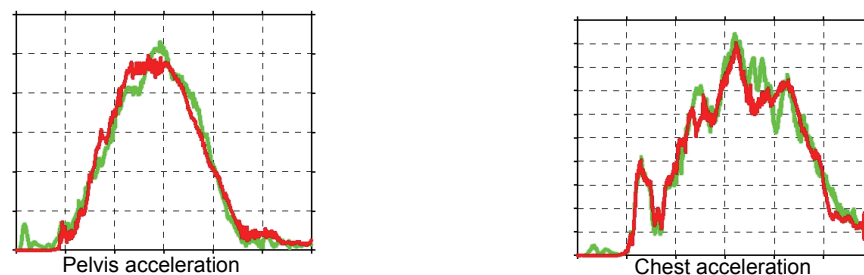

Figure 3. Agreement between conventional DYNA, and simplified DYNA model.

This simulation environment allows a continuously evolving occupant system model. Typically, a simple DYNA parametric model is constructed, using basic occupant package and vehicle structural assumptions, which is used for component target setting. As component geometry becomes available, detailed predictive FE representations are introduced progressively into the system model, allowing component development in an efficient system environment, and building up to predictive system model. Following vehicle testing, simple parametric representation of some components can be reintroduced, to allow quick test matching in these areas, whilst study or tuning of other areas progresses. Although the CPU run-time requirements are larger than corresponding multibody dynamics models, they still permit interactive daytime working.

#### Keywords:

Crash simulation, frontal occupant, interior systems, DYNA

## Simplified FE Simulation of Frontal Occupant Restraint Systems

Richard Brown, David Coleman, Ian Bruce  
Jaguar Land Rover, Coventry, UK. Arup, Solihull, UK.

Context – development process



Development process challenges:



CAE – led process that is:

- Reduced development time scales
- Increasing test requirements
- System complexity
- Design efficiency - optimisation
- Zero prototypes

- Predictive
- Efficient
- Integrated

Scope of frontal occupant restraint system



Components that significantly influence dummy injury values

- Airbags
- Seat belts
- Knee bolsters
- Glovebox
- Steering column
- Steering wheel
- Seat
- Carpet
- Dummy
- Body structure pulse and intrusion

Traditional multi-body dynamics frontal occupant system development



Good for:

- Parametric
- Stiffness characteristics for load paths
- Target setting
- Test-based system tuning
- Short run times

Bad for:

- Component development
- Integrated vehicle system
- Limited predictive capability without test data

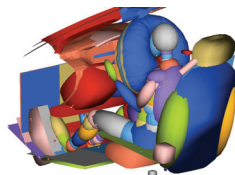

### Finite element frontal occupant system development



Good for:

- Component geometry and material properties representation
- Component development
- Predictive capability

Bad for:

- Parametric stiffness optimisation
- Quick test matching
- Run time

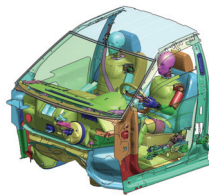

### Parallel development strategy



Multibody dynamics



Finite Element

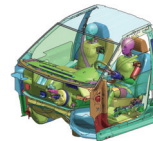

System tuning

Component development



Limited predictive capability without test data

Predictive

Efficient tuning (run time, parametric)

Efficient geometry representation

High test reliance

High geometry reliance

Parallel development strategy



Multibody dynamics

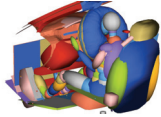

System tuning



Limited predictive capability without test data

Efficient tuning (run time, parametric)

High test reliance

Finite Element

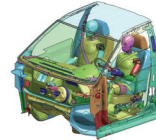

Component development



Predictive

Efficient geometry representation

High geometry reliance

Two software environments

Two sets of models

Intermediate models awkward

Comparisons difficult

Results different

Commercial equation



Duplicated:

- Licence cost
- Restraints and component models
- Process development cost
- Skill set maintenance and training

Integrated DYNA frontal occupant system development



- Parametric / geometric functionality – for full flexibility
- Compatible with conventional DYNA – for intermediate models
- Common restraints models – to reduce complexity and cost
- Common dummy models – for consistency and comparison
- Same processes – for efficient use of resources
- Usable run time – for large scale optimisation and one-off comparison

Status



- New programmes running DYNA only
- Improved process efficiency
- Focussed development effort
- Cost reduction

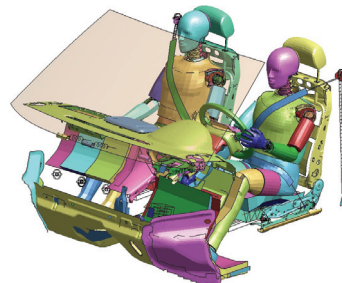

Detailed solution →

# Simplified FE Simulation of Frontal Occupant Restraint Systems

Ian Bruce – Arup

Richard Brown – Jaguar Land Rover

7<sup>th</sup> European LS-DYNA Conference – Salzburg May 2009

ARUP

## Defining the components of the sled model

The first task was to investigate the behaviour of the full model, find the main parts that interact with the occupant and group these into a number of component sets.

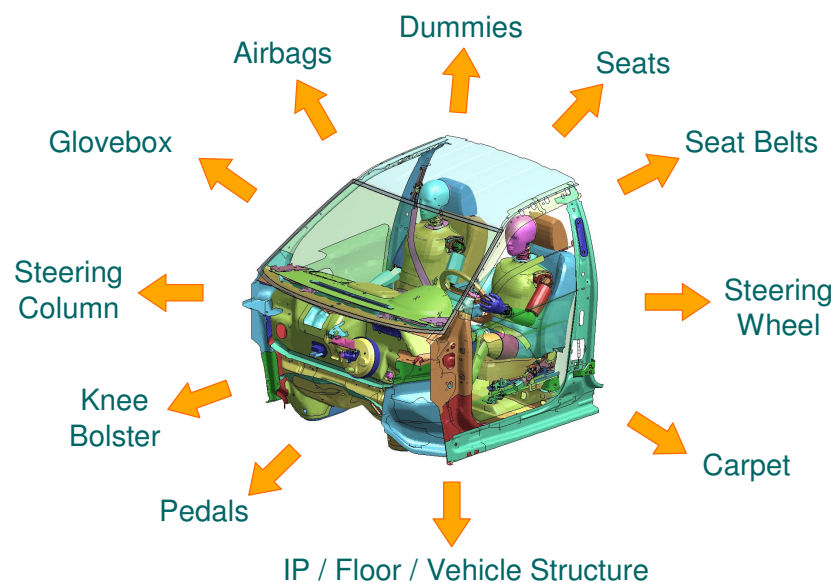

7<sup>th</sup> European LS-DYNA Conference – Salzburg May 2009

ARUP



## Defining the components of the sled model

A judgement was then made as to whether or not a particular component could be simplified or if the full detailed model was needed for accuracy.

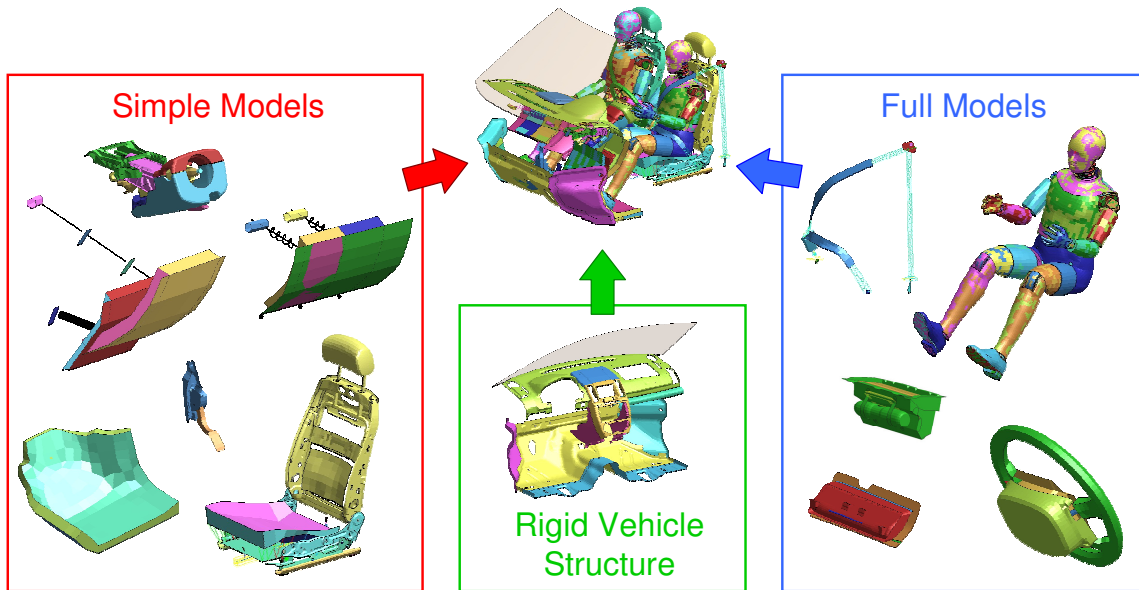

7<sup>th</sup> European LS-DYNA Conference – Salzburg May 2009

ARUP

## Simplified model development

The main building block for constructing these simplified models was a rigid plate mounted on a spring.

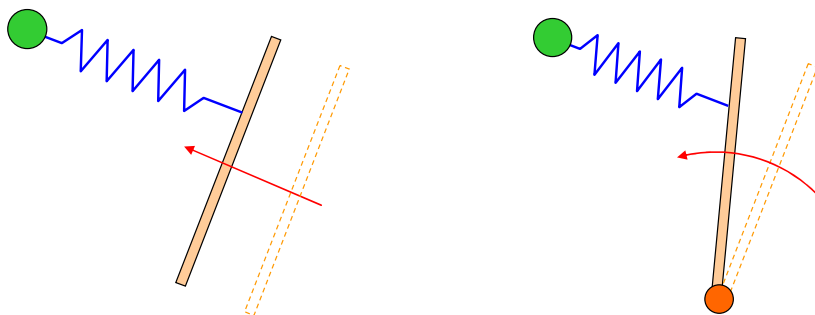

### Advantages

- short runtime
- easily adjustable force deflection behaviour
- can be combined in parallel or in series to provide a more complex response

7<sup>th</sup> European LS-DYNA Conference – Salzburg May 2009

ARUP

## Simplified model development

Each of the components was investigated under a number of loading conditions to find the main deformation modes that the simplified model would need to replicate.

Knee Bolster Loading Test  
35kg cylinder at 10m/s

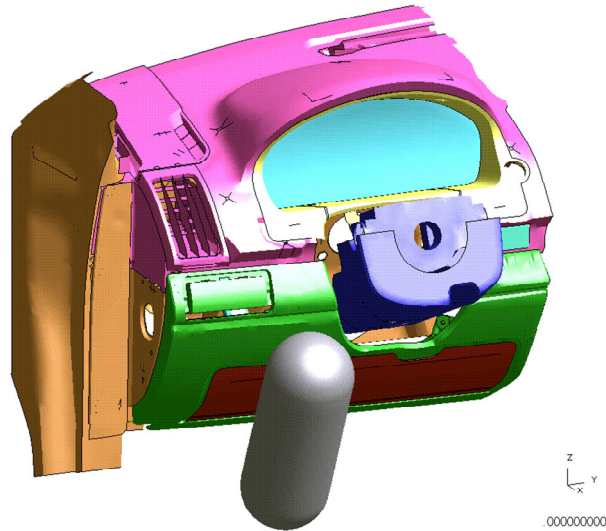

## Simplified model development

Simplified models of the components were constructed and taken through a number of design iterations until a robust and reasonably accurate representation of the full model was achieved.

Design progression of the simplified model for the knee bolster

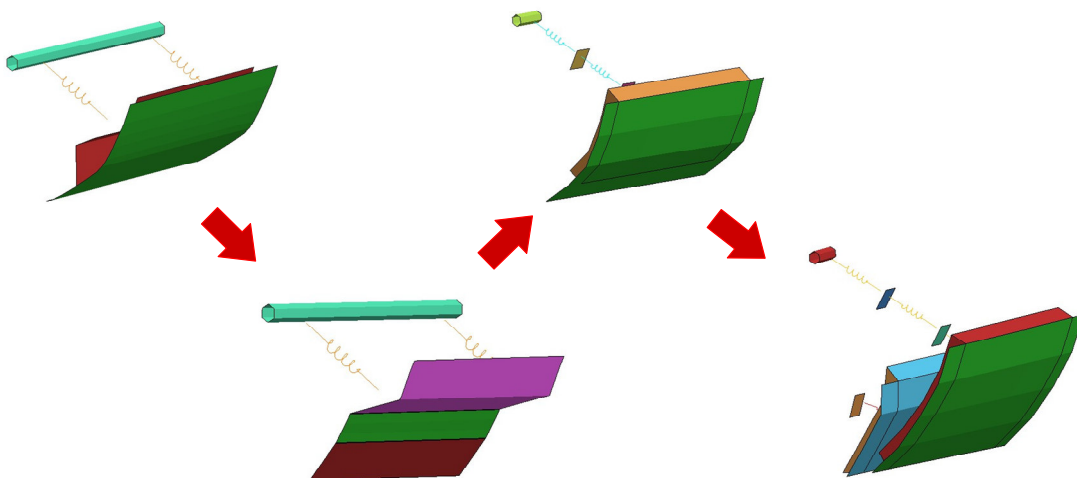

## Simplified model development – Seat Model

First the seat was split up into its main components.

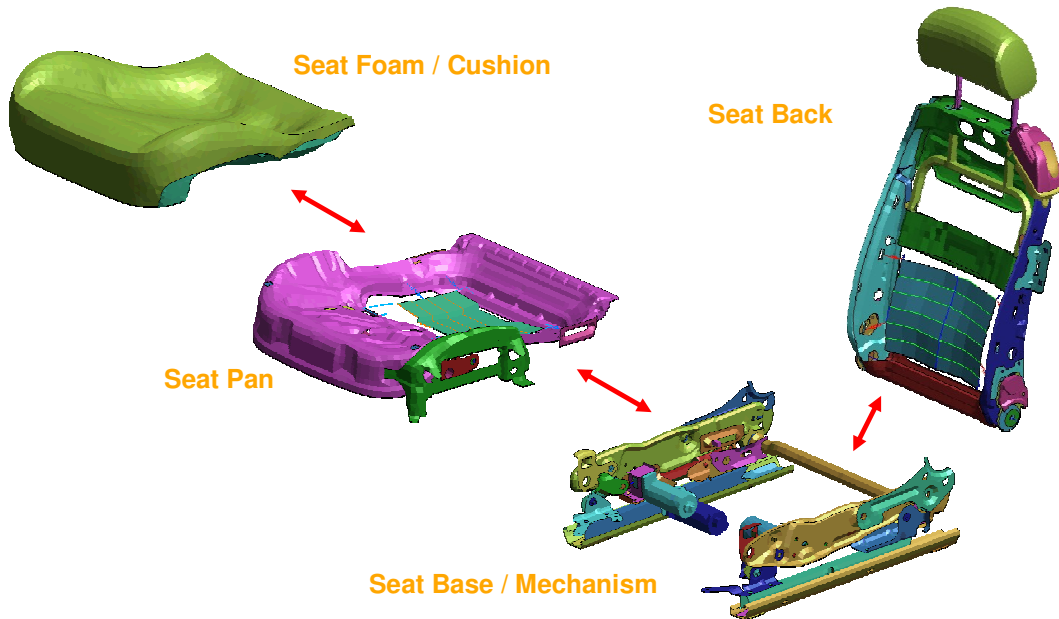

7<sup>th</sup> European LS-DYNA Conference – Salzburg May 2009

ARUP

## Simplified model development – Seat Foam Model

The initial method investigated used a series of hinged plates and beams but this was found to have stability problems. Therefore another method was tried using a single layer of solid elements and this was found to give good results.

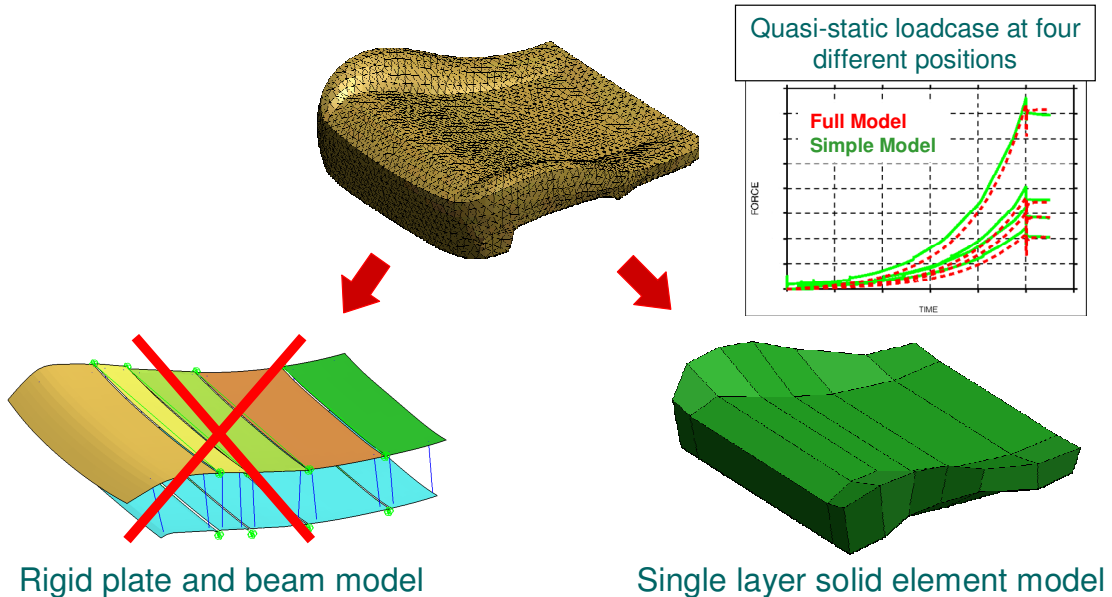

7<sup>th</sup> European LS-DYNA Conference – Salzburg May 2009

ARUP

## Simplified model development – Seat Pan Model

The stiffness of the seat pan was modelled using a series of discrete beams connecting the bottom surface of the seat foam to a rigid plate.

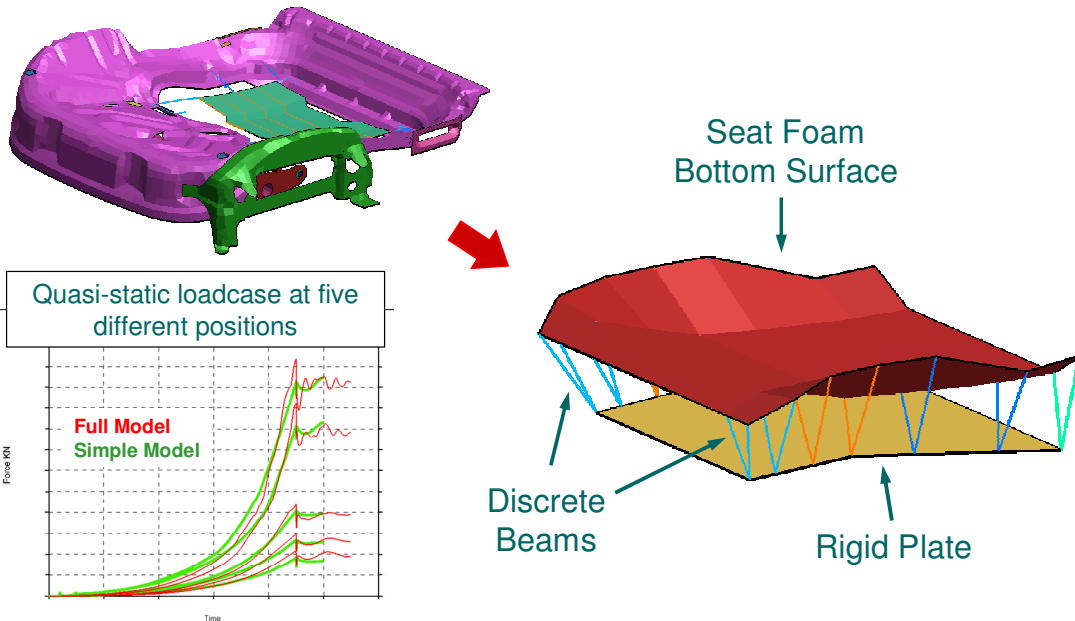

7<sup>th</sup> European LS-DYNA Conference – Salzburg May 2009

ARUP

## Simplified model development – Seat Base Model

The base was modelled as a simple parallelogram mechanism using rigid parts and joints. A series of springs were used to model the vertical stiffness.

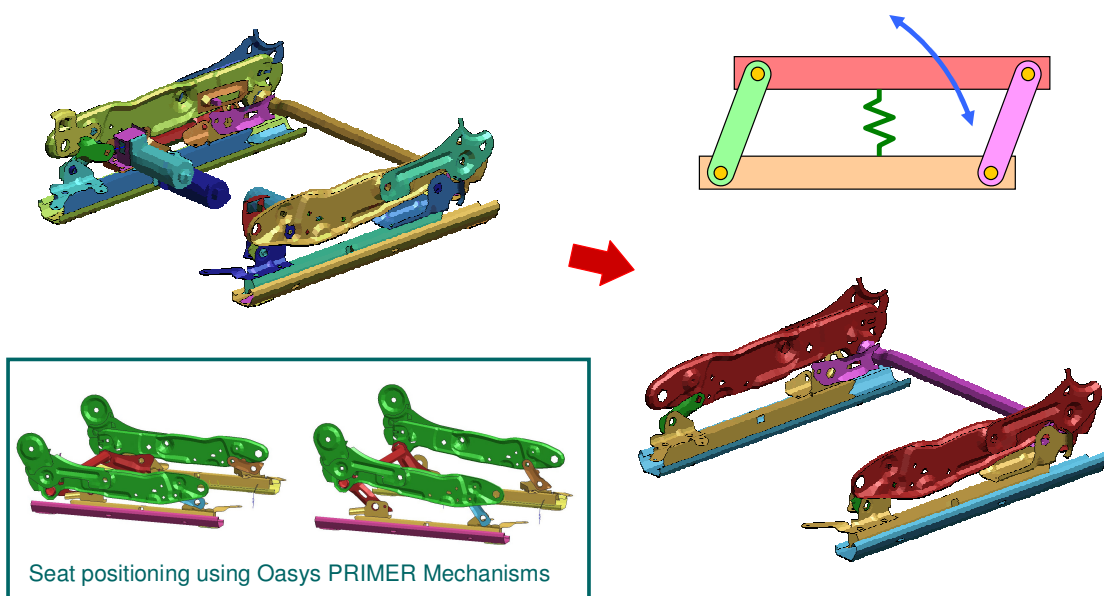

7<sup>th</sup> European LS-DYNA Conference – Salzburg May 2009

ARUP

## Simplified model development – Seat Model

The various simplified components of the seat model were combined and the results from a belt only sled test used to refine and correlate this complete seat model.

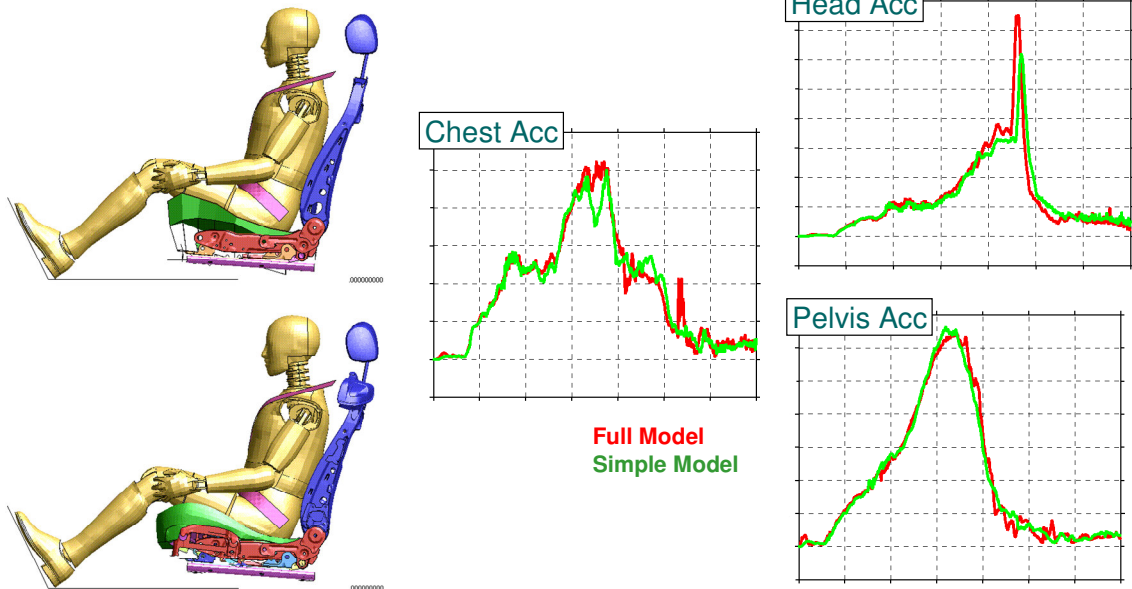

7<sup>th</sup> European LS-DYNA Conference – Salzburg May 2009

ARUP

## Full sled model comparison

The simple models for the individual components (seat, glovebox etc) were then taken and combined into a number of sled models along with those parts that couldn't be simplified such as the airbags and seatbelts.

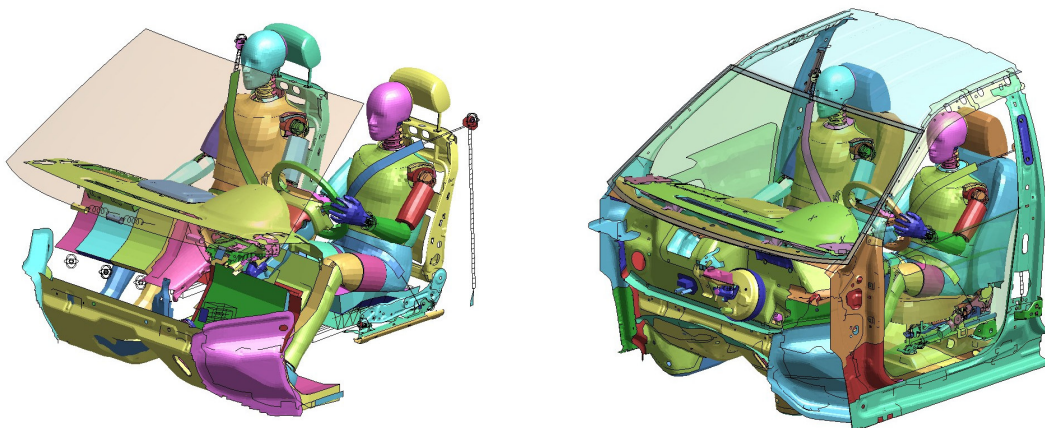

Simplified Sled Model  
(Belted 50% HIII Dummy)

Original Full Sled Model  
(Belted 50% HIII Dummy)  
(Runtime optimised)

7<sup>th</sup> European LS-DYNA Conference – Salzburg May 2009

ARUP

## Full sled model comparison

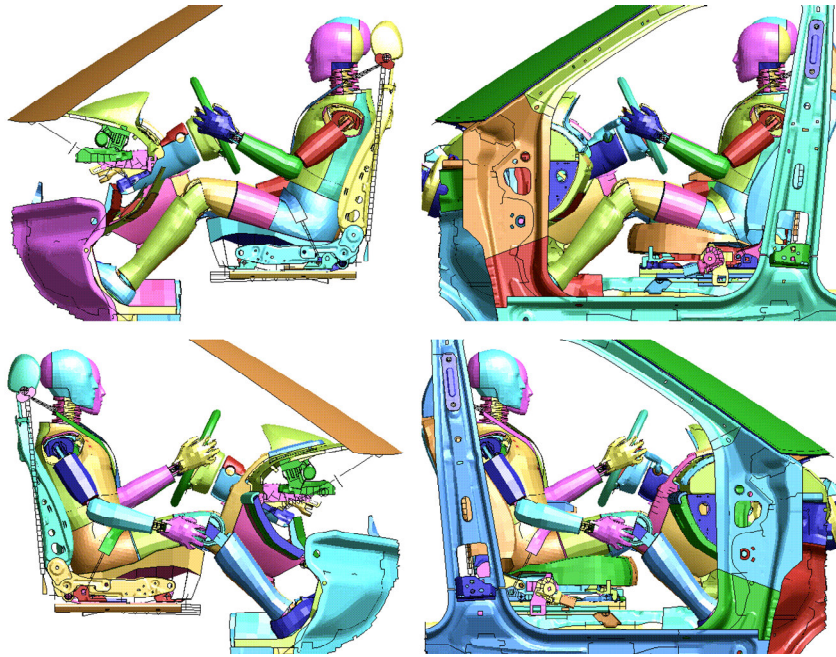

Simplified Sled Model

Original Full Sled Model

## Full sled model comparison

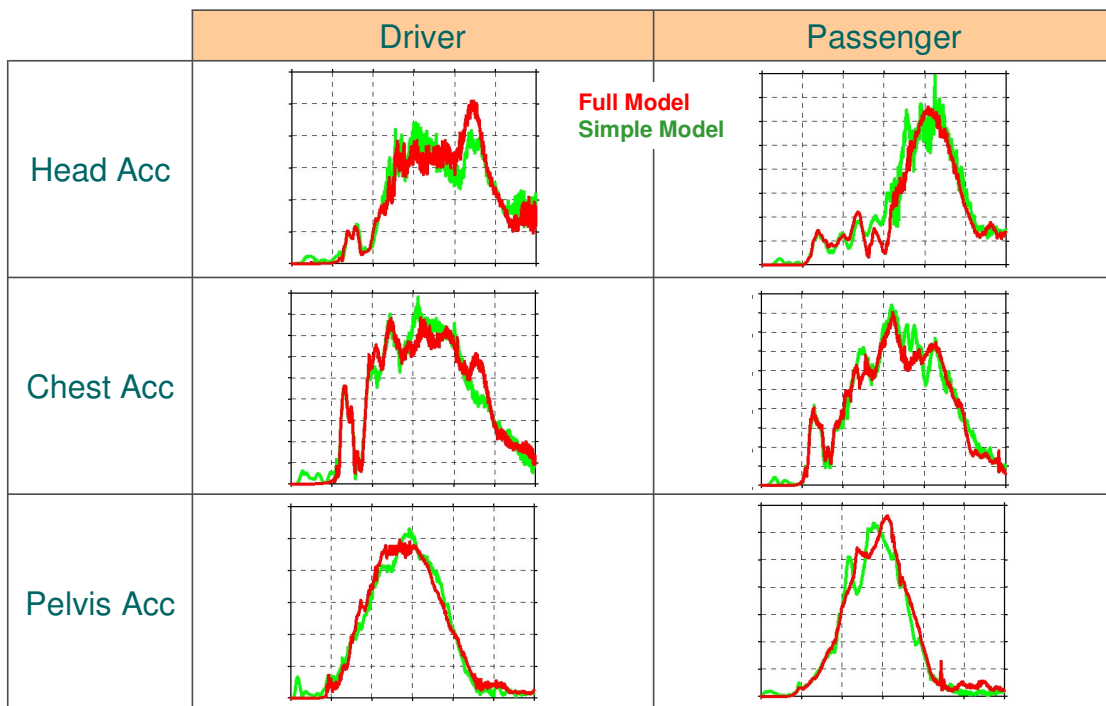

## Full sled model comparison

	Full Model (Runtime optimised)	Simple Model	Reduction
Sled Model 2 Dummies 3 Airbags 2 Seatbelts	6hrs 51mins	4hrs 15mins 2hrs 50mins (modular dummy)	38% 59% (modular dummy)
Sled Model No Dummies 3 Airbags 2 Seatbelts	3hrs 18mins	38mins	81%
Sled Model No Dummies No Airbags No Seatbelts	2hrs 36mins	6mins	96%

## Conclusions

- A method of modelling each of the main components was found that was robust and accurate enough for system level.
- The runtimes for a sled model were sufficiently reduced to allow interactive working.
- The main CPU cost is now the dummy models and use of the modular dummy can help to reduce this.
- The simple and detailed models can be quickly and easily interchanged.