

FEA Information

WORLDWIDE NEWS



August 2004

Participant's Articles, Information, Product Announcements

03	FEA Information: Letter To The Engineering Community
04	LEAP: Derailment and Crash Simulation of Waterfall Train Accident
13	ANSYS and Battle Readiness: Prognostic Model Keeps Helicopters Flying
17	CAD-FEM GmbH
19	PACE Program FEA Information Participants in The Pace Program

Directories

20	Hardware & Computing and Communication Products
21	Software Distributors
23	Consulting Services
24	Educational Participants
25	Informational Websites

FEA News/Newswire /Publications

26	News Page & Events
27	Newswire: Paracel Announces Cyclone LX Scalable Linux Cluster for LS-DYNA
28	Newswire: Intel® Itanium® 2-Processor-Based SGI® Altix® Servers Help Propel Procter & Gamble Productivity And Innovation

FEA Information Inc.

President & CEO:

Marsha Victory

Editor:

Trent Eggleston

Managing Editor:

Marsha Victory

Technical Editor:

Art Shapiro

Technical Writers:

Dr. David Benson

Uli Franz

Steve Pilz

Reza Sadeghi

Graphic Designer:

Wayne L. Mindle

The content of this publication is deemed to be accurate and complete. However, FEA Information Inc. doesn't guarantee or warranty accuracy or completeness of the material contained herein. All trademarks are the property of their respective owners. This publication is published for FEA Information Inc., copyright 2003. All rights reserved. Not to be reproduced in hardcopy or electronic copy.

Note: All reprinted full articles, excerpts, notations, and other matter are reprinted with permission and full copyright remains with the original author or company designated in the copyright notice

**FEA Information Inc.
Trent Eggleston & Marsha Victory**

August 2004 – Announcements

We welcome Paracel: **Paracel, Inc.**[®], a leading provider of applied high-performance computing™ solutions. Including, the availability of Paracel Cyclone™ LX, a highly scalable Linux cluster that has been optimized for the performance of LS-DYNA.

Art Shapiro, FEA Information Inc. Technical Editor, will be teaching LS-DYNA for Heat Transfer & Thermal-Stress Problems, Sept. 20- 21 at LSTC.

Travel: Marsha Victory in September will be attending the JRI conference in Japan and additionally traveling to China to visit MSC.Software China, ANSYS China and ETA China.

Software/Hardware/OS:

LSTC has a new Release: SMP Version ls970.5434.

Hardware and OS of FEA Information Inc. Participants that run LS-DYNA in 64bit mode: (alpha order)

AMD Opteron – Linux
FUJITSU Prime Power - SUN OS 5.8
FUJITSU VPP
HP PA8000 – HPUX
HPIA64 – HPUX or Linux
HP Alpha – True64
IBM Power 4 –AIX 5.1
Intel IA64 – Linux
NEC SX6
PARACEL Cyclone LX - Linux
SGI Mips – IRIX6.5
SGI IA64 – Altix

Asia: We have added a publication to the website www.ls-dyna.cn operated by FEA Information Inc.

Contact us to contribute to the FEA News or the FEA Websites.

Sincerely,

Trent Eggleston & Marsha Victory

Derailment and Crash Simulation of Waterfall Train Accident
© Copyright Jindong Yang and Nick Foster, 2004
LEAP Pty Ltd

1. INTRODUCTION

On 31 January 2003, a four car passenger train on the run from Sydney Central railway station to Port Kembla derailed about 2 kilometres south of Waterfall railway station.

Figure 1-1 shows the accident scene. The driver of the train and six passengers were fatally injured. Many other passengers suffered serious injuries.



Figure 1-1: The accident scene

Considerable media coverage was given to speculation concerning the causes of the accident. Numerous theories were put forward and portrayed in the media. The theories included: problems with the track, excessive speed, poor maintenance, inadequate safety management, motor power failure, brake failure, human error, other human factors, mechanical failure, vandalism or sabotage to the rails.

A Special Commission inquiry into the Waterfall rail accident was initiated by the NSW government to investigate the causes of the accident. Many consultants and investigators were employed by the Special Commission, Ministry of Transport of NSW, State Rail Authority (SRA) and other parties. The investigation took more than 27,000 man hours.

An interim investigation report [1] was published by the Special Commission in January 2004 and presented the following facts from the investigation:

- There was no evident causes of the accident;
- The train driver, having died in the accident, was not available to provide information on events that occurred following the departure of the train from Waterfall railway station.
- The train guard claimed not to have any recollection of the accident and was unable to give any verbal evidence.
- The possibility of a significant mechanical malfunction was not readily identifiable.
- The data logger fitted to the train was not operative on 31 January 2003, therefore the no pre-crash data was available.

Although many passengers were able to give vivid accounts of the accident, no witness able to explain why the train behaved as it did. This is significant because the mechanisms of derailment in this situation were therefore totally unknown. For these reasons the investigation had to rely almost entirely upon technical analysis to provide a factual basis as to what occurred.

LEAP Pty Ltd was commissioned by Ministry of Transport to conduct computer simulations of the Waterfall train derailment and post-derailment behavior to provide insight into the sequence of events. The computer simulation formed an important part of the technical analysis.

The objectives of the simulation were:

- Determine the speed at which the Tangara passenger train would theoretically overturn at a left curved track; with a radius of approximately 240 m.
- Reconstruct the accident events using computer simulation and identify the causes of, the main damage to the train structure and the injuries to the passengers.

The simulations were conducted using LS-DYNA, an engineering dynamics analysis software package. This software has been widely used in the automotive, aerospace and railway industries for improving structural crashworthiness and designing safer vehicles [2] and [3].

The simulation of vehicle crash response involves many complex mechanisms. These mechanisms include:

- Nonlinear material behavior
- Large deflections and rotations
- Contacts at interfaces between structural components
- Fracture and failure of structural elements, welds, and fasteners

LS-DYNA is able to model the mechanisms mentioned above providing input parameters such as, material properties, geometry of the structure and surroundings, and the physics of the environment, accurately represent reality.

The simulation was divided into two parts:

- Derailment simulation using rigid body dynamics FE model.
- Crash simulation using deformable body FE model.

2. THE DERAILEMENT SIMULATION

The objectives of the derailment simulation were to

- Determine the speed that would cause rollover derailment at the location that was identified by the scuff and runoff marks.
- Establish the initial conditions for subsequent deformable body crash simulations.

The four-car train consists of two identical control trailer cars (CTC) and two motor cars (MC). Figure 2-1 shows the details of the analysis model. The train structure was modeled as a rigid body connected by springs, dampers, revolute joints and pin joints to the wheels and bogies. The track geometry was imported from survey data. At the curved section of track there was 100mm super elevation. The rail and wheel profiles were modeled based on engineering drawings. The wheel to rail interface was modeled as rigid body contact. A friction coefficient of 0.3 was used for this interface.

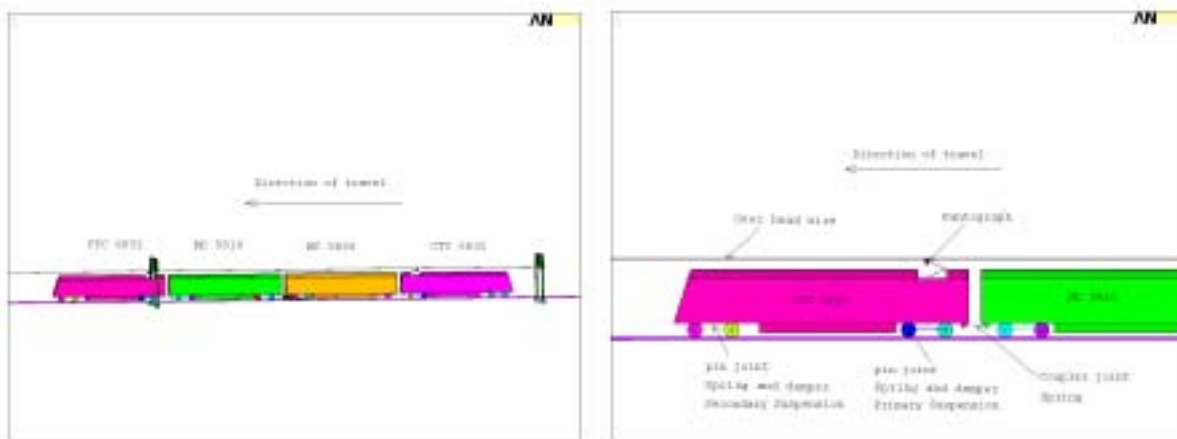

Figure 2-1 The analysis model

2.1 Derailment Simulation Results

A series of simulations were conducted with initial velocities ranging from 100 Km/h to 125Km/h. The computer simulation results showed that when the initial velocity of the train was set at 117 km/h, the train overturned and derailed at the location matching evidence collected at the accident sight. It was observed that with a higher initial velocity, the train derailed earlier in the curved track, while at a lower initial velocity, the train either derailed later or does not derail. Figure 2-2 shows the overturning and the derailment of the train at a velocity of 117 km/h.



Figure 2-2 The derailment of the train

The derailment simulation results also show, the derailment process including, carriage roll over, wheel runoff, and the carriage travel over the track and surrounding ballast. The velocity at the time immediately prior to impact with stanchion SW40+805 was calculated to be 98 km/hr. This velocity was used as initial velocity for the crash simulation.

3. CRASH SIMULATION

The objectives of the deformable body crash simulation were to reconstruct the accident events and identify the main causes of damage to the train structure and injuries to the passengers.

3.1 Finite Element Model

A finite element model was created encompassing the train carriages, tracks, surrounding landscape, stanchions, overhead wiring and the nearby rock cutting. Four carriages of the train were included in the simulation. The first two carriages were modeled in detail, while the last two carriages were modeled with less detail as the impact and the damage to the last two cars was relatively insignificant. Figure 3-1 shows the over all FE mesh used for this simulation.

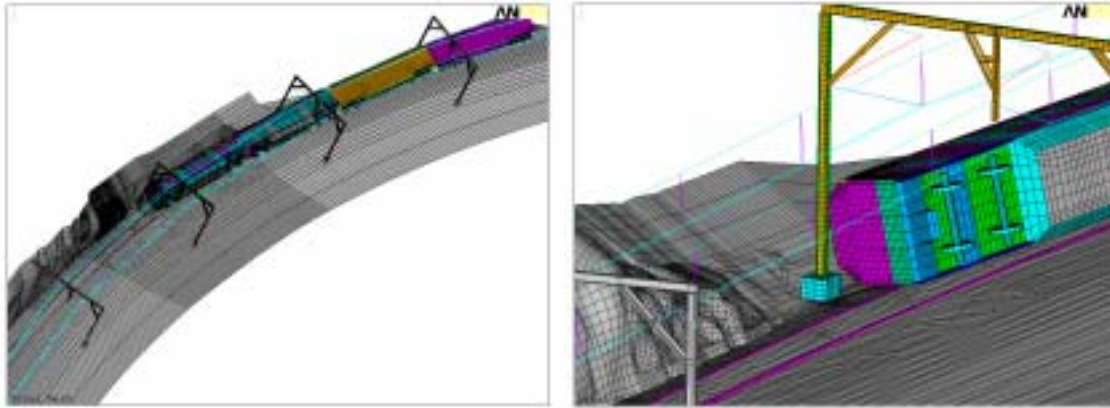

Figure 3-1 – The Finite Element Model

The friction coefficient is very important to the analysis. However the exact value of the coefficient of friction is difficult to determine due to the large number of contributing factors.

In the finite element model the rock face, outer train surfaces, ballast and ground are modeled with relatively large elements. The element size is in the order of 100mm. In reality, these surfaces, when considered on a micro level, are very rough and irregular. For example, the ballast surrounding the tracks and the rock face has a highly irregular surface and varying friction properties. All these factors are important when selecting a global friction coefficient. A global friction coefficient of 0.7 was chosen for the analysis and it was shown to give sensible results.

The centre of gravity of the carriages is an important factor in obtaining accurate physical behavior during the simulation. The finite element model included the structural members of the train explicitly. However items such as seats, stairs and other non-structural members were not explicitly modeled. To account for these components the densities of the structure were adjusted to give the correct total mass and overall centre of gravity of the train.

3.2 Crash Simulation Results

The animation files crash-top.avi, crash-side.avi and crash-front.avi show the sequence of events of the accident.

Model verification was completed by comparing the following results indicated by the simulation with photographs taken following the accident:

- Final resting position of the train
- Structural damage to the carriages

The simulation results were also compared with other physical evidence such as the geological evidence collected by Dr Hubble [4].

Figure 3-2 compares the resting position indicated by the simulation with the actual accident scene photo.



Figure 3-2: The resting position

Figure 3-3 and Figure 3-4 compare the simulated damage and deformation of the leading car and the second car with the photos of the damaged carriages. Good correlation was demonstrated between the simulation results and the physical evidence.



Figure 3-3: Leading car damage

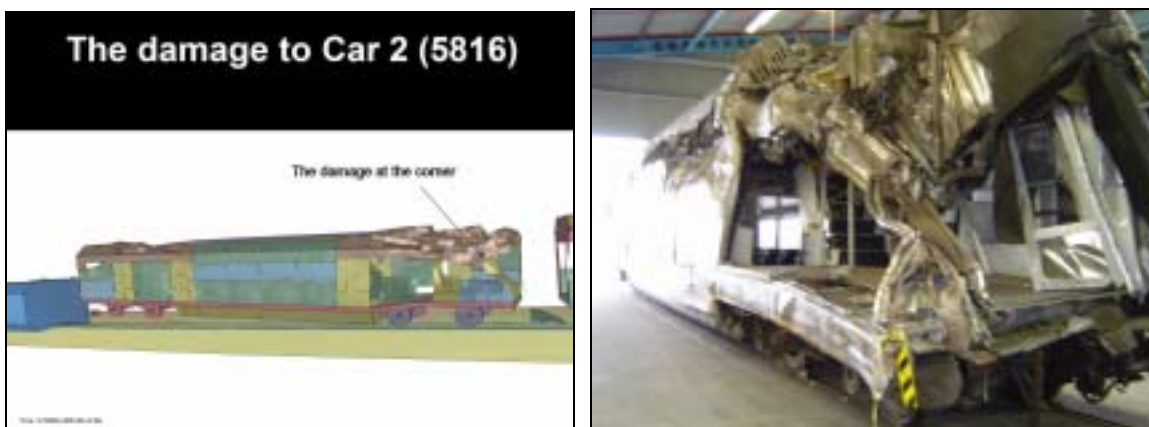
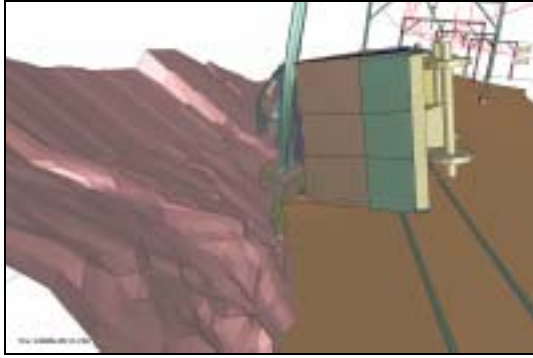

Figure 3-4: Second car damage

The following critical events were identified by the computer simulation. These observations were made in the context of viewing the simulation results and the snap shots (Figure 3-5):

1. The train slid on its side on one rail with its roof edge sliding on the bed of rail ballast. The leading carriage first collided with the concrete footing of stanchion SW40+805, and then the stanchion itself. It pulled the 25-mm diameter star anchor bar out of ground and carried the stanchion - with its concrete footing forward (see Figure 3-5 (1)).
2. The concrete footing jammed between the rock cutting and the inverter on the forward section of the roof of the leading car. This resulted in significant deformation of the inverter and collapse of the right front roof structure into the cabin space. The concrete footing then broke off the stanchion (see Figure 3-5 (2)).
3. The AC unit was thrown out of its mounting bay during the impact with the rock wall. It can also be seen that the stanchion has been bent 90 degrees (see Figure 3-5 (3)).
4. The leading car impacted the rock cutting and slid up the natural rock ramp for a few meters before uprighting itself and finally dropping off the ramp (see Figure 3-5 (4)). The main damage to the front top structure of leading car was caused by impact with the rock cutting, the stanchion and its footing.
5. The coupler between the first and second carriage broke due to an impact or compressive force. After the coupler was broken, the second car impacted into the back of the leading car (see Figure 3-5 (5)). The two cars then separated.
6. The passengers in the upper deck of the leading car were thrown out of the carriage during the upright turn of the leading car (Figure 3-5 (6)). The passengers' simulated landing locations are within a 5 metre range of the actual resting locations.
7. The second car impacted with the protruding rock wall and slid along the ramp. The main damage to the second car occurred during this impact (see Figure 3-5 (7)).
8. The AC Unit which forms part of the rear roof of the fourth car (6832) impacted with stanchion SW40+773 and brought it down (see Figure 3-5 (8)).



(1)

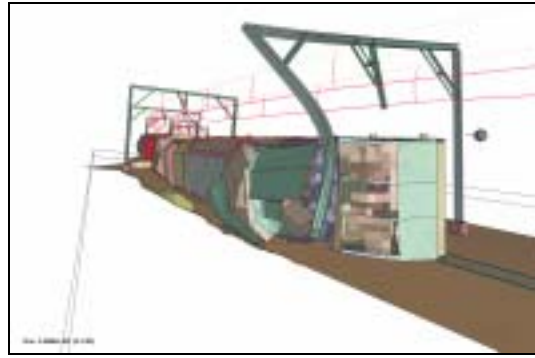

(2)

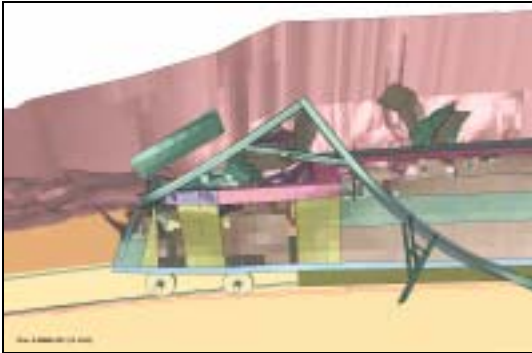

(3)



(4)

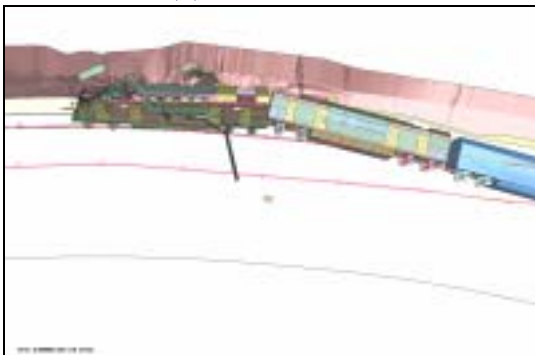

(5)

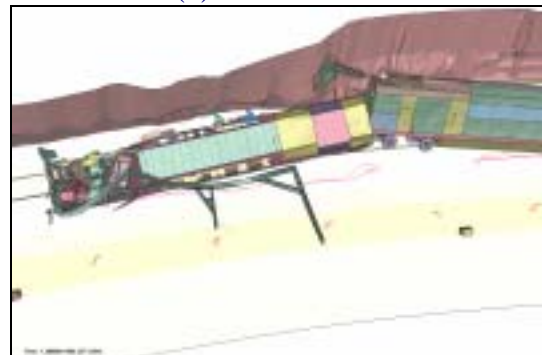

(6)

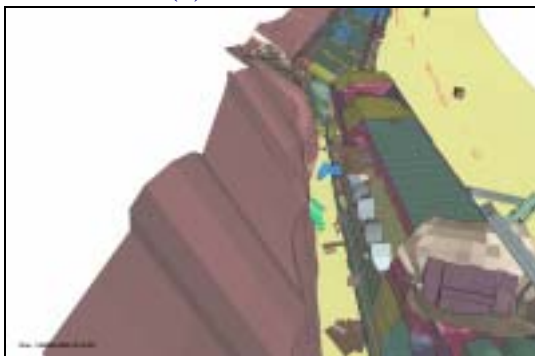

(7)

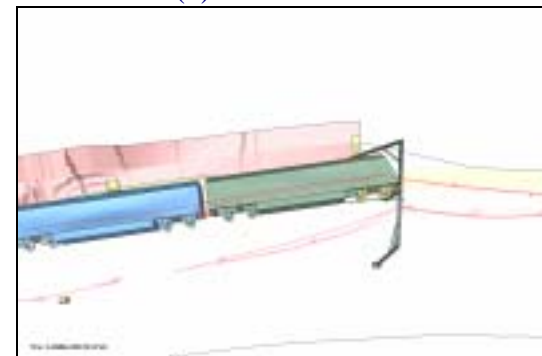

(8)

Figure 3-5: The timeline of critical events

4. DISCUSSION AND CONCLUSION

The simulation result shows good correlation with the physical evidence gathered, including, the carriages resting positions and structural damage, and the stanchions deformed shape and resting position.

The simulation also reproduced the crash sequence of events and demonstrated the possible mechanism of ejection of the driver and passengers. The predicted driver and the passengers landing locations show reasonable correlation to the physical evidence.

The FEA simulation work was highly regarded by the Special Commission with the simulation results extensively used in the Commissioner's Interim report [1] to explain what might have happened during the accident.

5. REFERENCES

[1] Special Commission of Inquiry into the Waterfall Rail Accident Interim Report, January 2004, The Honourable Peter Aloysius McInerney QC,

http://www.waterfallinquiry.com.au/InterimReport/InterimReport_pdf.htm.

[2] Evaluation of Passenger rail Vehicle Crashworthiness, S W Kirkpatrick etc. International Journal of Crashworthiness. Vol 6. No 1, pp95-106, 2001.

[3] Development of a computer model for prediction of collision response of a railroad passenger Car, S W Kirkpatrick, Proceedings of the 2002 ASME/IEEE Joint Rail Conference Washington, DC, April 23-25,2002.

[4] Police Waterfall accident site drawing. March 2003.

[5] Dr Tom Hubble, Geological Investigation of the Accident Site and Damaged Carriages. April 2003.

ANSYS and Battle Readiness: Prognostic Model Keeps Helicopters Flying
Article can be found on www.ansys.com white papers

EXECUTIVE SUMMARY

Challenge:

To calculate numerous physical values and create gear tooth models for UH-60 helicopters in U.S. Navy aircraft fleet.

Solution:

Implement ANSYS software to perform to convert gear tooth models into a finite element modeling and analysis (FEM/FEA) mesh that can be analyzed

Benefits:

- Increased mission reliability, better scheduled maintenance to reduce aircraft downtime, and dramatically decreased life cycle costs.
- Identified sensitivities and uncertainties in the effects of material properties and manufacturing defects on component capacity.
- Provided invaluable calibration of a prognostic model at various times in the life of a component so that it can be evaluated both in terms of long-term capability prediction (asset management) and more near-term damage minimization (fault accommodation).

Introduction:

For 20 years, the U.S. has asked its military to do more with less. Even as resources are trimmed, the armed forces are asked to take on new missions in faraway places. All too often, this is done with equipment that is far beyond the service life for which it was designed. Despite their increasing age, aircraft remain in service because replacements are not being acquired.

As necessity is the mother of invention, so budget constraints and readiness pressures have led to analyzing problems and finding new solutions. Among the most scientific and ingenious is a program focused on gears from UH-60 helicopter transmissions in U.S. Navy aircraft.

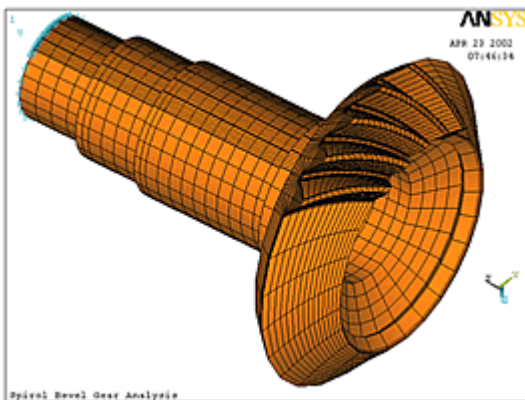

The Naval Air Systems Command has done extensive predictive and diagnostic work at its Helicopter Transmission Test Facility (HTTF) at Patuxent River. Funding is from the Defense Advanced Research Projects Agency (DARPA). The program also reaches down to consultants and engineering analysts in Upstate New York. Impact Technologies LLC, in Rochester, and a subcontractor in nearby Ithaca, Fracture Analysis Consultants Inc. (FAC), has undertaken analytical work.

Holding all this together is ANSYS Mechanical design and optimization software, which was used to calculate numerous physical values, to create the gear tooth models from proprietary gear-design geometry, and to convert that model into a finite element modeling and analysis (FEM/FEA) mesh for analysis.

Challenge:

Prognostics builds on 40-plus years of aircraft diagnostics and trouble-shooting. Diagnostic systems provide increased safety, but unfortunately, “they can require pulling components early while they still have a remaining useful life,” said William E. Hardman of the Naval Air Warfare Center Aircraft Division's Propulsion & Power Department, Patuxent River.

The goal is to create on-board systems to help commanders, maintenance crew chiefs and pilots make “go/no go” decisions in situations from routine maintenance to battlefields and rescues. Bringing prognosis capability on-board, NavAir believes, eliminates the potential for lost data, data dropout, and incorrectly processed data at the ground station.

Hardman, DARPA, NavAir and Patuxent River experts are building on their understanding of the relationships between existing diagnostic capability, damage evolution models, and rules and tools for prognosis of power drive train systems in combat aircraft. These are being integrated with the sciences of fracture mechanics (and fault progression), vibration-based mechanical diagnostics, component failure prediction, statistics, and material science.

In the program's early stages, NavAir experts evaluated statistical risk-reduction methods in terms of available and advanced mechanical diagnostics technologies. This was done in a series of seeded and propagation-fault tests. (In a “seeded” test, a crack or fault is intentionally induced rather than waiting for it to occur on its own.)

At the end of its work for NavAir, Impact concluded that useful and reliable prognostic models for helicopter gears can be built that will predict remaining life as a function of speed and load.

Solution:

Geometry and loading for three gear teeth were obtained in the form of finite elements written in ANSYS format from a proprietary gear-generation program, explained Lamirand, an Impact analyst who worked closely with Greg Kacprzynski, project manager for prognostics work at Impact, and Avinash Sarlashkar of Impact, who with Brad Lamirand, did the ANSYS work.

Using ANSYS, the model was expanded into a full 3-D model. “We did multiple static analyses at each tooth load increment,” said Lamirand. “These were post-processed in ANSYS to establish the static stresses over engagement of the three teeth. The crack propagation and trajectory model was developed working with the fully meshed ANSYS model.

The initial ANSYS model was meshed with about 31,000 ten-node Solid92 tetrahedral elements. The model was started with proprietary formatted gear data, plus associated load definitions for the pinion's

load history when teeth are completely engaged with a mating gear. The fracture mechanics model had 920,000 degrees of freedom and used 13 crack fronts, also known as load steps.

“Each load step was subjected to 18 load cases simulating instantaneous pinion loads,” Kacprzynski noted. “These corresponded to 18 discrete angular positions during the load-unload cycle for the pinion. As the crack grew, more elements were required to resolve the geometric details of the crack surface. By the 12th load step, the model reached nearly 1.4 million DOFs.”

The modeling effort was not to figure out what happens with a cracked gear tooth, but to see how high a level of confidence could be built into the prognostic model.

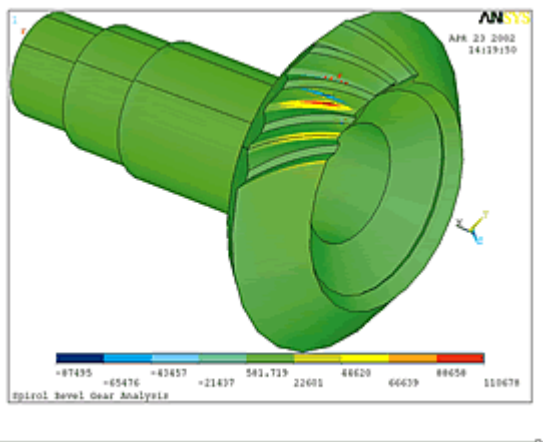

Kacprzynski's results showed that the mean predicted time to crack initiation was 11 hours while the actual time was 15 hours. In a second test, the mean prediction was 2.38 hours and the actual time was approximately 2.5 hours. This put the prognostics in the 98th and 63rd percentiles for accuracy and yielded (statistical) standard deviations of 1.64 and 0.36 hours, respectively.

The ANSYS calculations required tracking a moving load on the gear tooth surface with a continuously changing point of contact,” Sarlashkar explained. “There is a changing magnitude of load, which reaches its maximum as the tooth fully engages, then decreasing as the tooth disengages.

“This was handled with ANSYS multi-load analysis as a function of the tooth engagement,” he added. “This was a linear-elastic problem in an isotropic and homogeneous material using the preconditioned conjugate gradient solver.”

Benefits:

The ANSYS work by Impact was aimed at “developing validated models for predicting asset readiness,” Kacprzynski wrote. In his IEEE paper, he pointed out that NavAir results are used to:

- Provide realistic indications of state awareness, that is, health indicators such vibration features, and non-destructive evaluations related to actual material damage levels.
- Identify sensitivities and uncertainties in the effects of material properties and manufacturing defects on component capacity.
- Provide invaluable calibration of a prognostic model at various times in the life of a component so that it can be evaluated both in terms of long-term capability prediction (asset management) and more near-term damage minimization (fault accommodation).
- The key to a successful prognostic model for pinions is to link state awareness to material properties. “The software module,” he explained, “integrates advanced stochastic failure mode modeling, failure progression information from vibration features, and run-to-failure experience bases to enable IGB pinion gear failure predictions in the H-60 critical drive train.

“The failure rate prediction strategies are implemented within a probabilistic framework to directly identify confidence bounds associated with IGB pinion failure progression,” he added. “The results of seeded fault, run-to-failure tests on the IGB pinion gear are being compared to prognostic module predictions.”

Impact's results were verified in additional Patuxent tests. A pinion gear was driven to failure three times and Impact's prognoses closely matched what actually occurred in the test stand. “Mission reliability could be greatly increased, maintenance could be better scheduled to reduce aircraft downtime, and a dramatic decrease in life cycle costs could be realized,” Hardman said.

“What the ANSYS models provided us,” concluded Kacprzynski, “is the foundation upon which high-fidelity prognostic models for helicopter gears can be built that will predict remaining life as a function of speed and load.”

**CAD-FEM GmbH © Copyright CAD-FEM GmbH,
Christoph Mueller**

Excellence in Analysis Software Solutions & Services and Partner of LSTC since 1988

Since the founding days of the company in 1985, the CAD-FEM name has always stood for excellence in Analysis Software Solutions and Client Service. CAD-FEM's expertise, its long-standing experience, 75 highly trained engineers, longstanding and tight partnerships with major software makers such as LSTC or ANSYS and connections to numerous research institutes take the company one step ahead in a highly competitive market. Close cooperation between its departments and with its clients builds a solid foundation for efficient engineering.

LS-DYNA Services

CAD-FEM was one of the first LS-DYNA distributors ever and maintains a tight partnership with LSTC since 1988. The LS-DYNA Services group of CAD-FEM supports users of this software with a complete range of seminars and accompanying and additional services. Whenever analysis challenges get explicit, customers are welcome to contact CAD-FEM's experienced and highly skilled LS-DYNA team. As a member of an international group of companies with great experience in all kind of LS-DYNA application, CAD-FEM can offer through its local partners to customers support and service no matter where it is needed.

Visit www.lsdyna-portal.com!

Software and Hardware Sales

Since CAD-FEM offers only the world's leading finite element tools, customers can trust their numbers. No matter what your analysis needs to look like, products supported by CAD-FEM such as LS-DYNA, ANSYS, ANSYS CFX, ICEM CFD, LMS SYSNOISE or the formability analysis tools of FTI cover virtually the full spectrum of general-purpose simulation applications. A wide range of special-purpose tools completes our product line. A new service is eCADFEM (www.eCADFEM.com), where an increasing number of CAD-FEM's products is available for temporal use.

The LS-DYNA Portal:

A open internet platform for LS-DYNA users all over the world with latest news on LS-DYNA, general information on LS-DYNA, technical information on LS-DYNA, many LS-DYNA classes offered in different countries, a collection of demo examples which is steadily growing and a discussion forum, where registered users can place questions. The LS-DYNA Portal is maintained by CAD-FEM and is a cooperation of different European and worldwide LS-DYNA distributors
www.lsdyna-portal.com

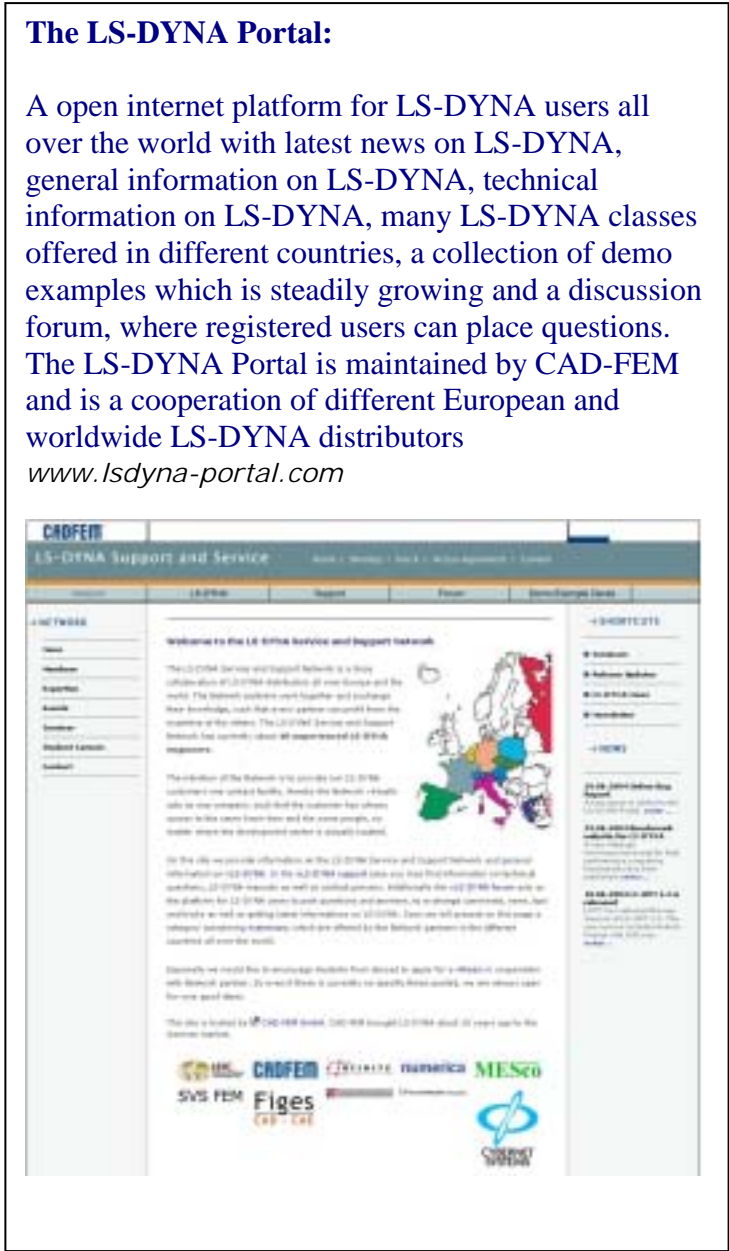

As CAD-FEM has teamed up with leading computer makers, customers can get exactly the hardware-software installation their business needs.

ANSYS Services

As well as for LS-DYNA, CAD-FEM offers also a complete range of services for another major finite element program, ANSYS.

Finite Element Consulting

Experienced specialists of the CAD-FEM consulting team are to help when customers face bottlenecks or require specific know-how. If a company can not apply finite element technology in its full range, CAD-FEM offers relief.

Research & Development

This CAD-FEM department is doing the customisation of existing software tools and the development of user, company or industry specific solutions, such as the worldwide successful Virtual Paint Shop tool. Also the tight cooperation with universities and research institutes is an important task of this group.

Knowledge-based Engineering

Apart from finite element analysis, CAD-FEM is pioneering applications for knowledge-based Engineering (KBE). The already long-term experience of CAD-FEM's KBE specialists is the key to an efficient implementation of these leading edge applications right the first time.

Visit us this year in Dresden at Germany's largest annual congress on FEA technology, the 22nd CAD-FEM Users Meeting – International Congress on FEM Technology. A broad range of workshops and lectures on LS-DYNA is offered, among our guests of honor will be Dr. John Hallquist. More information: **www.usersmeeting.com**.

www.cadfem.de

FEA Information Inc. Participants Support PACE



PACE supports strategically selected academic institutions worldwide, to develop the *automotive product life cycle management* (PLM) team of the future. PLM, as it relates to PACE, is an integrated, parametrics-based approach to all aspects of a product's life--from its design inception, through its manufacture, marketing, distribution and maintenance, and finally into recycling and disposal. Currently, PACE is focused on digital product development:

- Requirements and Planning (concept development)
- Concept Engineering (styling)
- Product Engineering (detailed design)
- Simulation (simulation, validation, optimization)
- Manufacturing Engineering (tooling, machining, 3-D plant layout)
- Managed Development Environment (product data management, supply chain management, digital collaboration)

Assisted by “PACE Contributor” and “PACE Supporter” companies, PACE provides hardware, software, training, automotive parts, industry projects, and much more to PACE Institutions around the world. Because of the emphasis of digital simulation (or CAE) in the PACE Program, some of the **FEA Information** companies have become PACE Contributors (e.g. Hewlett Packard, LSTC and MSC.Software).

To date, 41 academic institutions in Australia, Brazil, Canada, China, Germany, Mexico, South Korea, Sweden and the U.S. have been selected to participate in the PACE program. Twenty-six institutions have formally been announced. The value of contributions to date is over to \$2 billion (USD) in total.

For more information about PACE, check out the website: **www.pacepartners.org**.

FEA Information Inc. Participants Supporting PACE:



Hardware
&
Computing and Communication Products
(Listed in Alphabetical Order)



www.amd.com



www.fujitsu.com



www.hp.com



www-1.ibm.com/servers/deepcomputing



www.intel.com



www.nec.com



www.sgi.com



www.paracel.com

Software Distributors

Alphabetical order by Country

Australia	Leading Engineering Analysis Providers www.leapaust.au
Canada	Metal Forming Analysis Corporation www.mfac.com
China	ANSYS China www.ansys.cn
China	MSC. Software – China www.mscsoftware.com.cn
Germany	CAD-FEM www.cadfem.de
Germany	DynaMore www.dynamore.de
India	GissETA www.gisseta.com
India	Altair Engineering India www.altair.com
Italy	Altair Engineering Italy www.altairtorino.it
Italy	Numerica SRL www.numerica-srl.it
Japan	Fujitsu Limited www.fujitsu.com
Japan	The Japan Research Institute www.jri.co.jp
Korea	Korean Simulation Technologies www.kostech.co.kr
Korea	Theme Engineering www.lsdyna.co.kr

Software Distributors

Alphabetical order by Country

Russia	State Unitary Enterprise www.ls-dynarussia.com
Sweden	Engineering Research AB www.erab.se
Taiwan	Flotrend www.flotrend.com.tw
USA	Altair Western Region www.altair.com
USA	Engineering Technology Associates www.eta.com
USA	Dynamax www.dynamax-inc.com
USA	Livermore Software Technology Corp. www.lstc.com
USA	ANSYS Inc. www.ansys.com
UK	Oasys, LTC www.arup.com/dyna/

Consulting Services Alphabetical Order By Country

Australia Manly, NSW www.leapaust.com.au	Leading Engineering Analysis Providers Greg Horner info@leapaust.com.au 02 8966 7888
Canada Kingston, Ontario www.mfac.com	Metal Forming Analysis Corporation Chris Galbraith galb@mfac.com (613) 547-5395
India Bangalore www.altair.com	Altair Engineering India Nelson Dias info-in@altair.com 91 (0)80 2658-8540
Italy Torino www.altairtorino.it	Altair Engineering Italy sales@altairtorino.it
Italy Firenze www.numerica-srl.it	Numerica SRL info@numerica-srl.it 39 055 432010
UK Solihull, West Midlands www.arup.com	ARUP Brian Walker brian.walker@arup.com 44 (0) 121 213 3317
USA Irvine, CA www.altair.com	Altair Engineering Inc. Western Region Harold Thomas info-ca@altair.com
USA Windsor, CA www.schwer.net/SECS	SE&CS Len Schwer len@schwer.net (707) 837-0559

**Educational & Contributing Participants
Alphabetical Order By Country**

India	Dr. Anindya Deb	Indian Institute of Science
Italy	Professor Gennaro Monacelli	Prode – Elasis & Univ. of Napoli, Federico II
Russia	Dr. Alexey I. Borovkov	St. Petersburg State Tech. University
USA	Dr. Ted Belytschko	Northwestern University
USA	Dr. David Benson	University of California – San Diego
USA	Dr. Bhavin V. Mehta	Ohio University
USA	Dr. Taylan Altan	The Ohio State U – ERC/NSM
USA	Prof. Ala Tabiei	University of Cincinnati
USA	Tony Taylor	Irvin Aerospace Inc.

Informational Websites

FEA Informational websites	www.feainformation.com
TopCrunch – Benchmarks	www.topcrunch.org
LS-DYNA Examples (more than 100 Examples)	www.dynaexamples.com
LS-DYNA Conference Site	www.ls-dynaconferences.com
LS-DYNA Publications to Download On Line	www.dynalook.com
LS-DYNA Publications Index	www.feapublications.com
LS-DYNA Forum	http://portal.ecadfem.com/Forum.1372.0.html
LS-DYNA CADFEM Portal	http://www.lsdyna-portal.com

www.feainformation.com
News for July Archived on Site & Events

July 05	No Weekly Posting
July 12	AMD – Official Technology partner of the USPS Pro Cycling Team
	NEX – The SX-6 series
	Numerica – Distributor in Italy – sales, consulting, training
July 18	IBM – eServer p5
	ANSYS - Workbench
	ANSYS China - Conference 2004 during September
July 26	MSC. Software – Aerospace Defense
	CAD-FEM Users´ Meeting - Internationale FEM-Technologietage mit ANSYS CFX & ICEM CFD Conference

2004	Events & Announcements
Sept. 7-9	The Seventh International Conference on Computational Structures Technology, Lisbon, Portugal
Sept. 21-22	2004 Japanese LS-DYNA Users Conference hosted by JRI, will be held at Akasaka Prince Hotel in Tokyo.
Sept 21-23	ANSYS CHINA - Annual User Conference
Oct. 11-12	The Nordic LS-DYNA Users' Conference 2004 will be held at Quality Hotel 11, Goteborg
Oct.14-15	3rd local LS-DYNA Conference - Bamberg, Germany sponsored by DYNAmore
Oct. 18 - 20	MSC.Software's 2004 Americas Virtual Product Development Conference - October 18 - October 20 2004 Hyatt Regency Huntington Beach, CA, USA
Nov 10-12	22. CAD-FEM Users' Meeting 2004 - International Congress on FEM Technology & ANSYS CFX @ ICEM CFD Conference
2005 & 2006	
May 25-26, 2005	5th European LS-DYNA Conference - The ICC, Birmingham UK
July 25-27	8th U.S. National Congress on Computational Mechanics – Austin, Texas
June 3, 2006	9th LS-DYNA International Users Conference – Dearborn, Michigan

Paracel Announces Cyclone LX Scalable Linux Cluster for LS-DYNA

PASADENA, Calif. – July 30, 2004 - Paracel, Inc.[®], a business unit of the Celera Genomics Group of Applera Corporation and a leading provider of applied high-performance computing™ solutions, today announced the availability of Paracel Cyclone™ LX. Cyclone LX is a highly scalable Linux cluster that has been optimized for the performance of LS-DYNA. This enables design engineers to run complex simulations faster and to run multiple jobs simultaneously.

“By combining Paracel’s extensive experience optimizing HPC systems for performance with LSTC’s state-of-the-art simulation software, Paracel can configure solutions that provide increased price/performance. This helps our customers shorten their product development lifecycle, ultimately leading to expanded marketshare and increase revenue,” said Jenifer Audette, HPC product manager.

Paracel tested a variety of platforms to determine configurations of Cyclone LX that offer the best price/performance. Configurations of Paracel Cyclone LX 2000 series based on the AMD Opteron™ processor demonstrated the best price/performance while also offering the capability to handle 32- and 64-bit applications. Cyclone LX is also available in configurations based on Intel® Xeon™ and Intel® Itanium®2 processors.

All systems include Paracel’s HPC Services to help organizations quickly deploy their new high performance computing infrastructure. In addition, Paracel provides one point of contact for support of the hardware, operating system, middleware and application integration. This reduces the need to work with multiple vendors for troubleshooting and problem resolution.

More information on benchmarks, Paracel Cyclone LX and Paracel’s integrated systems for manufacturing applications can be found at: <http://www.paracelcyclone.com>.

About Paracel Cyclone: Paracel Cyclone is a turnkey Linux cluster solution, pre-configured for optimal performance of customer applications. Available in an array of configurations and with virtually unlimited scalability, Cyclone can accommodate a wide variety of applications. Paracel offers a range of options including the fastest processors from Intel® and Advanced Micro Devices™, high-speed interconnects such as Myrinet®, Dolphin™, and Gigabit Ethernet, a selection of memory and large-scale RAID storage options.

About Paracel, Inc.: Paracel (<http://www.paracel.com>) is a leading provider of applied high-performance computing solutions to solve the most technically challenging problems. Founded in 1992 to commercialize high-volume data analysis technology, Paracel today is a premier provider of integrated turnkey systems and software for over 500 customers worldwide. Paracel is headquartered in Pasadena, California and is a wholly owned subsidiary of Celera Genomics.

Contact: Amanda Sheldon - Paracel, Inc. - (626) 744-2086 - amanda.sheldon@paracel.com

© Paracel Cyclone and Paracel are trademarks and registered trademarks of Paracel, Inc. All others trademarks are property of their respective owners.

Intel® Itanium® 2-Processor-Based SGI® Altix® Servers Help Propel Procter & Gamble Productivity And Innovation

SANTA CLARA, Calif. and MOUNTAIN VIEW, Calif., May 24, 2004 - Intel Corporation and SGI today announced that the Procter & Gamble Company has recently doubled its deployment of Intel® Itanium® 2-processor-based SGI® Altix® systems used in the manufacturing and packaging design of some of its most popular consumer products. The products include Folgers* coffee, Charmin* bath tissue, Bounty* paper towels, and Pampers* diapers.

The deployment helped save the beauty and health care product company time and money by enabling Procter & Gamble (P&G) to concurrently implement complex design projects.

The Procter & Gamble Corporate Engineering Technology Group increased the Altix high-performance computing capacity to a total of 64 Itanium 2 processors and 96 GB of shared memory in January of this year. P&G's approximately 100-person design group is able to help eliminate costly and time-consuming physical product testing in developing its manufacturing equipment and product packaging by conducting more efficient product tests using "virtual" prototypes.

"In just a few months we've seen dramatic increases in both the speed with which our engineers are able to work through the design process and the breadth of perspective they can apply to development projects," said Tom Lange, associate director of Corporate Engineering Technologies at Procter & Gamble. "For instance, by using the Altix system's global shared memory architecture to access product design data, we were able reduce the time of our stress analysis testing on the Folgers canister lid by a month. This wouldn't have been as possible nor as easy had we applied a traditional PC-based cluster solution to this problem."

With help from the Itanium 2 processor-based SGI Altix system, P&G designers created the new Folgers AromaSeal* Canister. The structural challenges in replacing metal cans required significant computer-aided engineering (CAE) analysis and design input. In addition, CAE studies conducted on the Altix system also have helped designers achieve better-fitting Pampers diapers.

The P&G team also uses the Altix system to run a series of "what-if" scenarios to help P&G determine how to get maximum manufacturing output for key products such as Charmin and Bounty. By testing a range of aerodynamic variables, engineers were able to understand the speed and stability limitations of processing paper at high speeds. Paper dust and moving sheets are complicated and expensive to manage and even more expensive to change based on guesses alone. The team used the results of computer modeling to evaluate settings and airflow management features in order to help maximize the processing rate while supporting quality and reliability.

Prior to installing its initial 32-processor Itanium 2 processor-based Altix system, P&G only had enough computing power to run one complex job per person. With the newly expanded Altix deployment, P&G designers now have enough processing and memory capacity for each team member to run multiple what-if scenarios simultaneously. This enables them to make more informed design decisions related to product launches from the manufacturing process to final product packaging.

The SGI Altix system architecture handles large data sets with ease, helping to enable customers to achieve groundbreaking improvements in manufacturing, oil and gas exploration, homeland security, earth and environmental sciences research, and life sciences. Since its introduction in January 2003, the Altix system has set numerous records for sheer performance, and for its ability to efficiently run manufacturing, engineering and scientific applications across hundreds of processors in a Linux* operating environment.

About SILICON GRAPHICS | The Source of Innovation and Discovery™

SGI (NYSE: SGI), also known as Silicon Graphics, Inc., is the world's leader in high-performance computing, visualization and storage. SGI's vision is to provide technology that enables the most significant scientific and creative breakthroughs of the 21st century. Whether it's sharing images to aid in brain surgery, finding oil more efficiently, studying global climate or enabling the transition from analog to digital broadcasting, SGI is dedicated to addressing the next class of challenges for scientific, engineering and creative users. With offices worldwide, the company is headquartered in Mountain View, Calif., and can be found on the Web at www.sgi.com.

Intel, the world's largest chip maker, is also a leading manufacturer of computer, networking and communications products. Additional information about Intel is available at www.intel.com/pressroom. Intel and Itanium are trademarks or registered trademarks of Intel Corporation or its subsidiaries in the United States and other countries.

Silicon Graphics, SGI and Altix are registered trademarks, and The Source of Innovation and Discovery is a trademark of Silicon Graphics, Inc., in the United States and/or other countries worldwide. Linux is a registered trademark of Linus Torvalds in several countries.

* Other names and brands may be claimed as the property of others.