

LS-DYNA® – development status

RECENT ENHANCEMENTS IN LS-DYNA® FOR COMPOSITE MODELING

C. Liebold

03/2018 – STUTTGART - GER



OVERVIEW

MATERIAL MODELS

CFRP

SFRP

PRE- AND POSTPROCESSING

LAMINATE DEFINITION

HISTORY - VISUALIZATION

MATERIAL MODELS

Overview on available material models in LS-DYNA for CFRP

	Element	Failure criteria	New features
*MAT_054/055: ENHANCED_COMPOSITE_DAMAGE	Shell, Tshell, Solid	54: Chang 55: fiber: Chang matrix: Tsai-Wu	TI flag: for transversal isotropy for solid modeling 2WAY – flag for 2-way fiber behavior (DFAILT, DFAILC, YC, YT, SLIMT2, SLIMC2 are altered if this flag is set
*MAT_261: LAMINATED_FRACTURE_DAIMLER_PINHO	Shell, Tshell, Solid	Pinho	strain rate dependent strengths and fracture toughnesses via *DEFINE_CURVE and _TABLE
*MAT_262: LAMINATED_FRACTURE_DAIMLER_CAMANHO	Shell, Tshell, Solid	Camanho	strain rate dependent strengths and fracture toughnesses via *DEFINE_CURVE and _TABLE

MATERIAL MODELS

- *MAT_ANISOTROPIC_ELASTIC_PLASTIC (*MAT_157)

	1	2	3	4	5	6	7	8	
plasticity parameters	Card 1	MID	RO	SIGY	LCSS	QR1	CR1	QR2	CR2
elastic, anisotropic parameters	Card 2	C11	C12	C13	C14	C15	C16	C22	C23
	Card 3	C24	C25	C26	C33	C34	C35	C36	C44
	Card 4	C45	C46	C55	C56	C66	R00 or F	R45 or G	R90 or H
plasticity parameters	Card 5	S11 or L	S22 or M	S33 or N	S12	AOPT	VP		MACF
material coordinate definition	Card 6	XP	YP	ZP	A1	A2	A3		EXTRA
	Card 7	V1	V2	V3	D1	D2	D3	BETA	IHIS
failure parameters	Card 8	XT	XC	YT	YC	SXY	FF12		NCFAIL
	Card 9	ZT	ZC	SYZ	SZX	FF23	FF31		

- All these parameters can be initialized on the integration point, using the IHIS flag.
- The value IHIS defines, which information is written in the initial card.
- The input in the *INITIAL_STRESS_SHELL/_SOLID card overwrites the input in the „original“ material card.

MATERIAL MODELS

*MAT_ANISOTROPIC_ELASTIC_PLASTIC (*MAT_157)

- EXTRA = 1 (Tsai-Wu failure model) – 3D (Solids):

$$\left(\frac{1}{XT} - \frac{1}{XC}\right)\sigma_{aa} + \left(\frac{1}{YT} - \frac{1}{YC}\right)\sigma_{bb} + \left(\frac{1}{ZT} - \frac{1}{ZC}\right)\sigma_{cc}$$
$$+ \frac{1}{XT \cdot XC}\sigma_{aa}^2 + \frac{1}{YT \cdot YC}\sigma_{bb}^2 + \frac{1}{ZT \cdot ZC}\sigma_{cc}^2 + \frac{1}{SXY^2}\sigma_{ab}^2 + \frac{1}{SYZ^2}\sigma_{bc}^2 + \frac{1}{SZX^2}\sigma_{ca}^2$$
$$+ 2 \cdot F_{12}\sigma_{aa}\sigma_{bb} + 2 \cdot F_{23}\sigma_{bb}\sigma_{cc} + 2 \cdot F_{31}\sigma_{cc}\sigma_{aa} < 1$$

- with:

$$F_{12} = F12 \sqrt{\frac{1}{XT \cdot XC \cdot YT \cdot YC}}, \quad F_{23} = F23 \sqrt{\frac{1}{YT \cdot YC \cdot ZT \cdot ZC}}, \quad F_{31} = F31 \sqrt{\frac{1}{ZT \cdot ZC \cdot XT \cdot XC}}$$

- for plain stress elements, this reduces to:

$$\left(\frac{1}{XT} - \frac{1}{XC}\right)\sigma_{aa} + \left(\frac{1}{YT} - \frac{1}{YC}\right)\sigma_{bb} + \frac{1}{XT \cdot XC}\sigma_{aa}^2 + \frac{1}{YT \cdot YC}\sigma_{bb}^2$$
$$+ \frac{1}{SXY^2}\sigma_{ab}^2 + 2 \cdot F_{12}\sigma_{aa}\sigma_{bb} < 1$$

MATERIAL MODELS

*MAT_ANISOTROPIC_ELASTIC_PLASTIC (*MAT_157)

- EXTRA = 2 (Tsai-Hill failure model) – 3D (Solids):

$$(G+H)\sigma_{aa}^2 + (F+H)\sigma_{bb}^2 + (F+G)\sigma_{cc}^2 - 2H\sigma_{aa}\sigma_{bb} - 2F\sigma_{bb}\sigma_{cc} - 2G\sigma_{cc}\sigma_{aa} \\ + 2 \cdot N\sigma_{ab}^2 + 2 \cdot L\sigma_{bc}^2 + 2 \cdot M\sigma_{ca}^2 < 1$$

- H,F,G,N,L,M are expressed in terms of the stress limits, where the stress state defines whether the compressive- or the tensile strength limit enter the equation:

$$(G+H) = \frac{1}{X_i^2}; \quad (F+H) = \frac{1}{Y_i^2}; \quad (F+G) = \frac{1}{Z_i^2};$$

$$2N = \frac{1}{SXY^2}; \quad 2L = \frac{1}{SYZ^2}; \quad 2M = \frac{1}{SZX^2};$$

$$H = 0.5 \cdot \left(\frac{1}{X_i^2} + \frac{1}{Y_i^2} - \frac{1}{Z_i^2} \right); \quad F = 0.5 \cdot \left(\frac{1}{Y_i^2} + \frac{1}{Z_i^2} - \frac{1}{X_i^2} \right); \quad G = 0.5 \cdot \left(\frac{1}{X_i^2} + \frac{1}{Z_i^2} - \frac{1}{Y_i^2} \right)$$

MATERIAL MODELS

*MAT_ANISOTROPIC_ELASTIC_PLASTIC (*MAT_157)

- EXTRA = 2 (Tsai-Hill failure model) – Shells:

$$(G + H)\sigma_{aa}^2 + (F + H)\sigma_{bb}^2 - 2H\sigma_{aa}\sigma_{bb} + 2 \cdot N\sigma_{ab}^2 < 1$$

- with:

$$(G + H) = \frac{1}{X_i^2}; (F + H) = \frac{1}{Y_i^2};$$

$$2N = \frac{1}{SXY^2}; H = 0.5 \cdot \left(\frac{1}{X_i^2} \right)$$

- If these conditions are violated, the stress tensor will be reduced to zero over NCFail time steps. Default is 10.

For both failure options: all failure parameter can be defined as load curves to consider strain rate dependency. If the first strain rate value is negative, a ln – scale is considered for the strain rate.

MATERIAL MODELS

*MAT_ANISOTROPIC_ELASTIC_PLASTIC (*MAT_157)

$a_i \in 0,1$ for IHIS - calculation

*INITIAL_STRESS_SOLID:

$$IHISV = a_4 \cdot 16 + a_3 \cdot 8 + a_2 \cdot 4 + a_1 \cdot 2 + a_0$$

$$NHISV = 6a_0 + 21a_1 + 6a_2 + a_3 + 9a_4$$

*INITIAL_STRESS_SHELL:

$$IHISV = a_4 \cdot 16 + a_3 \cdot 8 + a_2 \cdot 4 + a_1 \cdot 2 + a_0$$

$$NHISV = 2a_0 + 21a_1 + 3a_2 + a_3 + 5a_4$$

flag	description	variables	number
a_0	material directions	q_{1i}, q_{3i}	6
a_1	anisotropic elastic stiffness	C_{ij}	21
a_2	anisotropic plasticity	F, G, H, L, M, N	6
a_3	hardening curve	LCSS	1
a_4	strength limits	XT, XC, ...	9

flag	description	variables	number
a_0	material directions	q_1, q_2	2
a_1	anisotropic elastic stiffness	C_{ij}	21
a_2	anisotropic plasticity	r_{00}, r_{45}, r_{90}	3
a_3	hardening curve	LCSS	1
a_4	strength limits	XT, XC, ...	5

PRE- AND POSTPROCESSING

LAMINATE DEFINITION

since R10.0
LSPP 4.5

Proper laminate definition for non-continuous physical plies across a single part and post-processing for multi-layered, patched materials can be achieved using either
*ELEMENT_SHELL_COMPOSITE_LONG with **non-zero Ply-IDs** or
*ELEMENT_SHELL_COMPOSITE, when using **MID=-1**.

This allows for the definition of zero-thickness integration points with a constant number of integration points in each element.



PRE- AND POSTPROCESSING

LAMINATE DEFINITION

since R10.0
LSPP 4.5

```
*ELEMENT_SHELL_OFFSET_COMPOSITE
$#  eid      pid      n1      n2      n3      n4      n5      n6      n7      n8
    1        1        2        3      11        9        0        0        0        0
$#      offset
    0.15
$#  mid1     thick1     b1  unused  mid2     thick2     b2
    1         0.1       0.0
    1         0.1       0.0
   -1         0.0       0.0
```



PRE- AND POSTPROCESSING

LAMINATE DEFINITION

since R10.0
LSPP 4.5

```
*ELEMENT_SHELL_OFFSET_COMPOSITE_LONG
$#  eid      pid      n1      n2      n3      n4      n5      n6      n7      n8
    1        1        2        3      11        9        0        0        0        0
$#      offset
    0.15
$#  mid1     thick1      b1      unused  plyid1
    1        0.1        0.0
    0        0.0        0.0
    1        0.1        0.0
    1        0.1        0.0
    0        0.0        0.0
```



PRE- AND POSTPROCESSING

LAMINATE DEFINITION – REMARKS:

For post-processing read both, keyword – input and d3plot

Select Option -> N/A gray fringe for grayed out display of zero-thickness IPs

since R10.0
LSPP 4.5

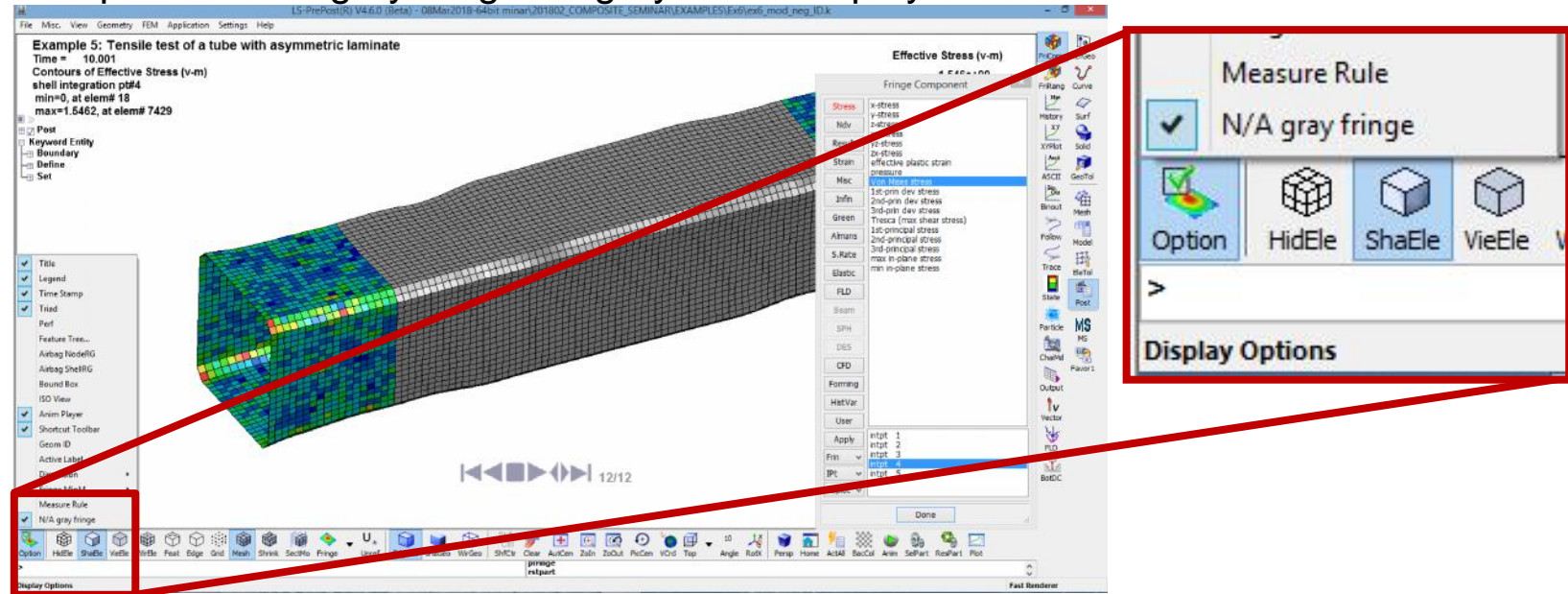

PRE- AND POSTPROCESSING

LAMINATE DEFINITION – REMARKS:

Meaning of history variables can be displayed using FriCopr->HistVAR, for specific material models (*MAT_54/55)

since R10.0
LSPP 4.5

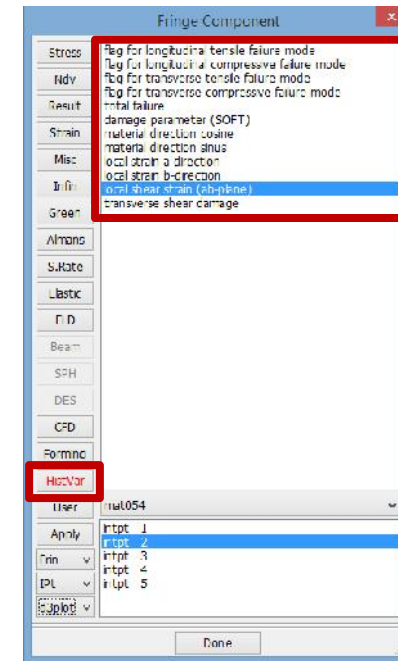
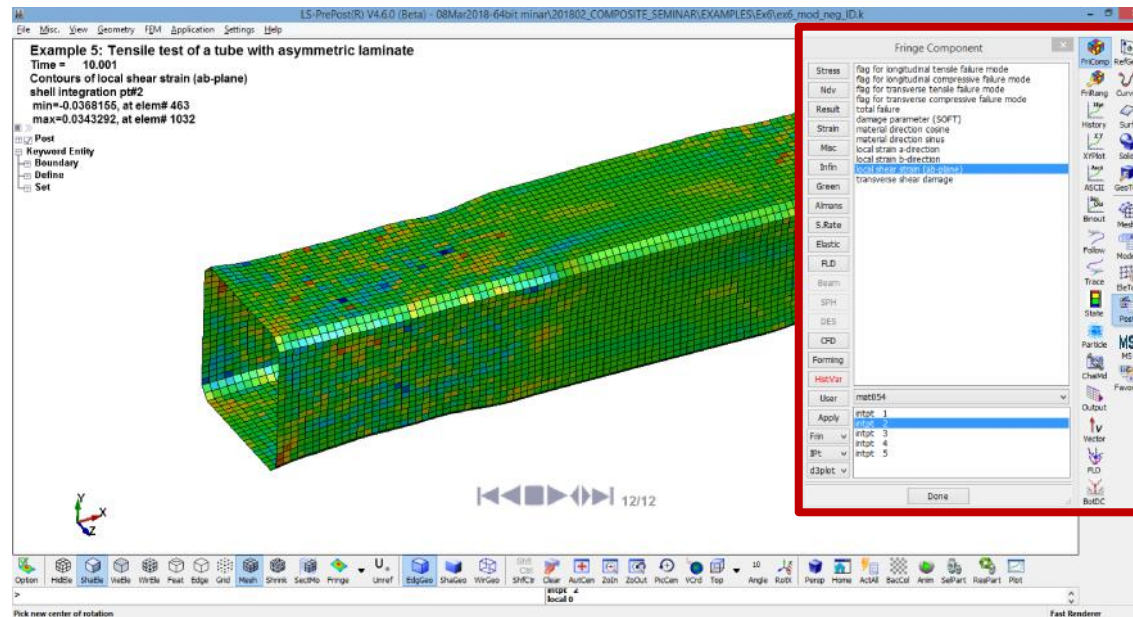

PRE- AND POSTPROCESSING

LAMINATE DEFINITION – REMARKS:

When loading keyword and d3plot, the user can switch between the different coordinate systems in the model

since R10.0
LSPP 4.5

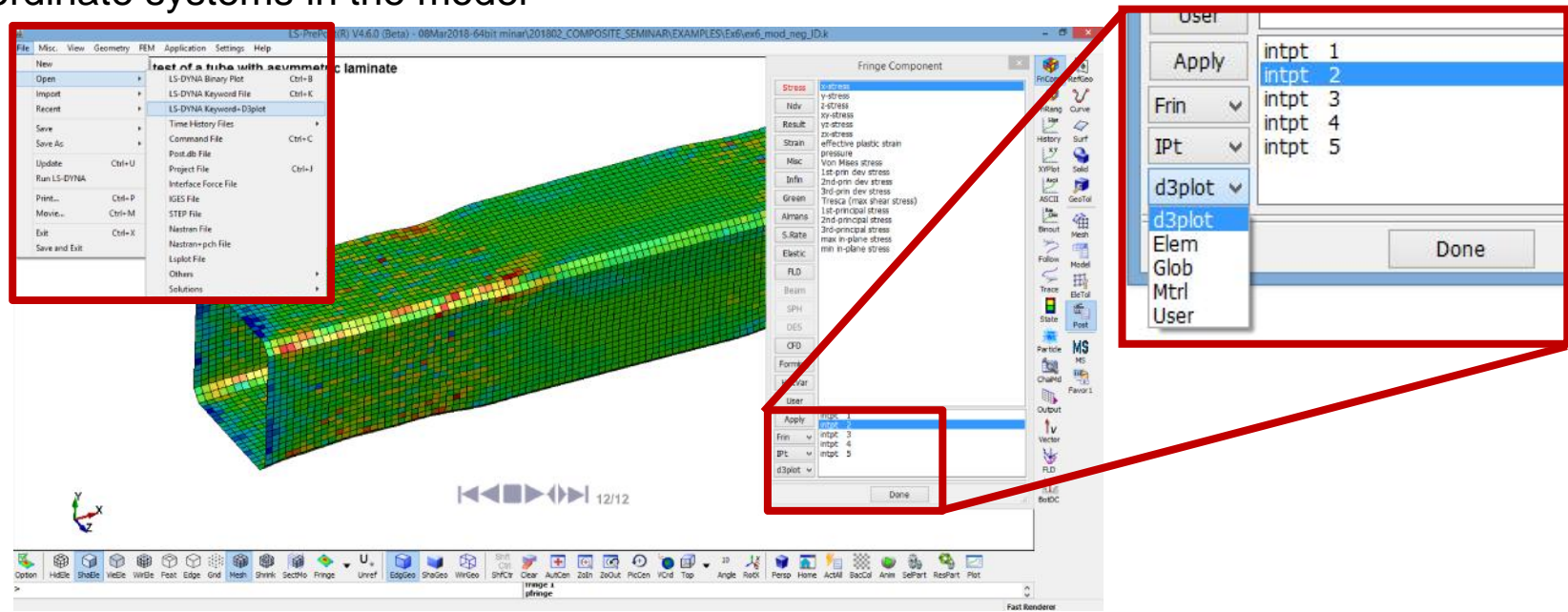

PRE- AND POSTPROCESSING

For composite materials (SFRP/CFRP), orientations are often stored and initialized as history variables

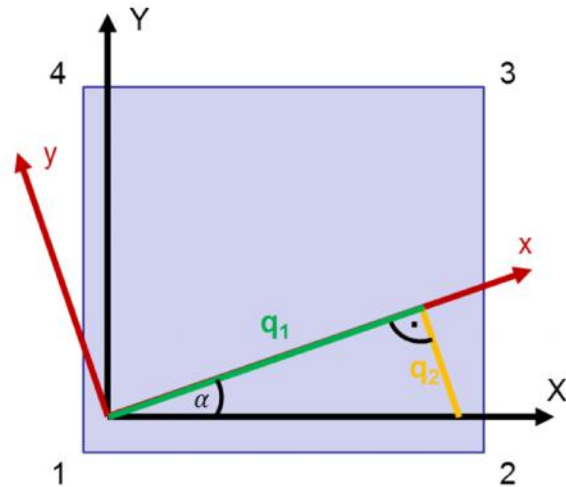

q_1 : material direction cosine
 q_2 : material direction -sine

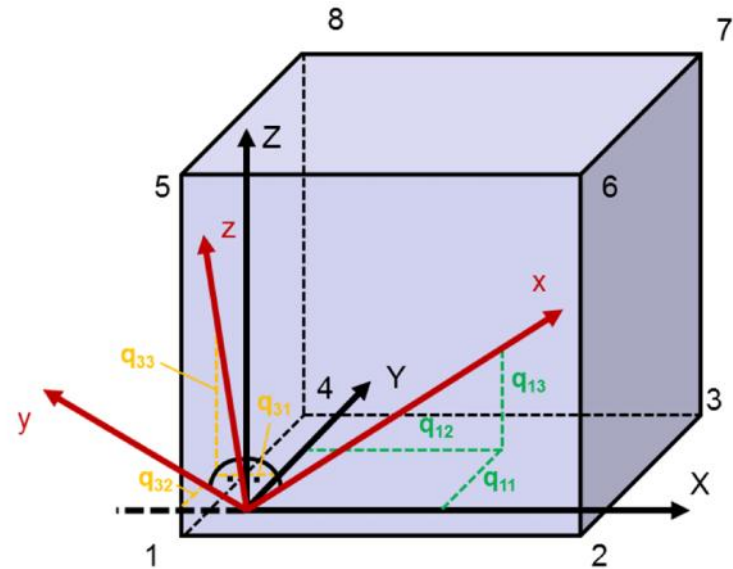

q_{11} : first vector to define mat. coord. system
 q_{31} : second vector to define mat. coord. system

PRE- AND POSTPROCESSING

HISTORY VISUALIZATION:

The user can visualize history variables as vector plot, referring to the element coordinate system when using a negative input

since R10.0
LSPP 4.5

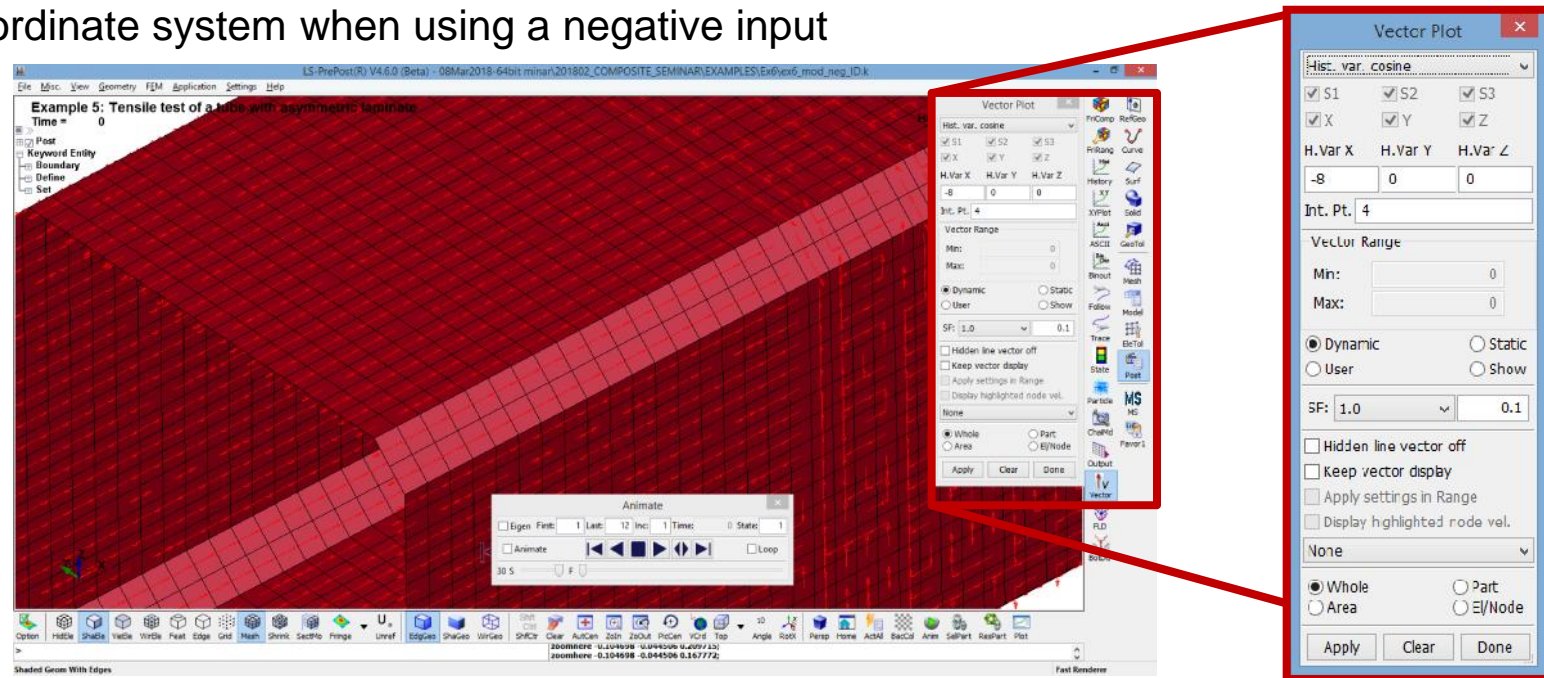

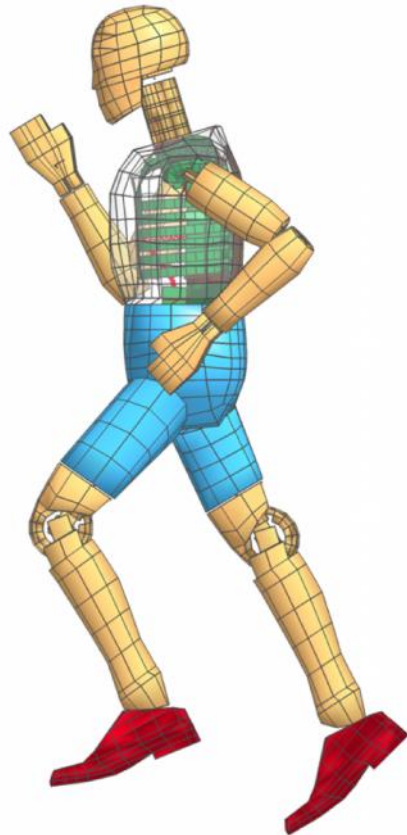

FIN

C. Liebold¹

¹DYNAmore GmbH
Industriestraße 2
70565 Stuttgart

cl@dynamore.de

The logo consists of a teal square on the left, followed by the word "DYNA" in large, bold, black capital letters, and the word "MORE" in smaller, teal capital letters below it.

A smaller version of the DYNA MORE logo, featuring a teal square, the word "DYNA" in black, and "MORE" in teal below it.